

Clevises with hardened cross hole

similar DIN 71 752/DIN ISO 8140/CETOP-standard

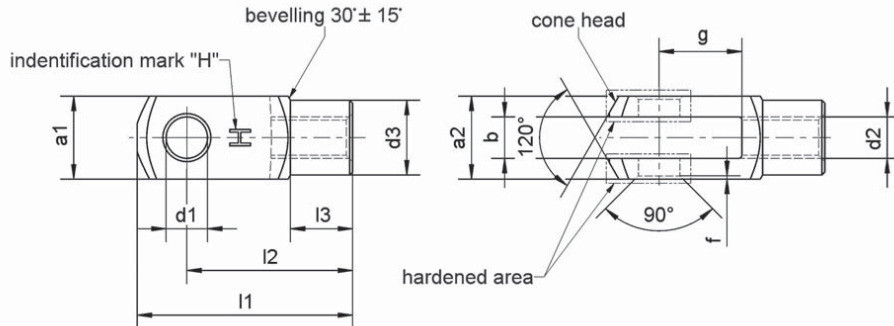

Example for ordering: Clevis with hardened cross hole, d1=10 mm,
slot length g=20 mm, with metric fine-pitch thread d2=M 10x1.25;
Clevis with hardened cross hole G 10x20, M 10x1.25
Order number: 14 20 0010 0020



mbo standard 20

Size	Order number	d1 H 9	d2 ¹⁾		b + 0.7 + 0.1	h ¹¹⁾ a1 ¹²⁾	a2 + 0.50 - 0.20	l1 ±0.5	l2 ±0.4	l3 ±0.2	d3 ±0.2	g ±0.5	f ±0.2	Mass (kg) per piece
			Regular thread	Fine-pitch thread										
G 4x8	10 20 0004 0008	4	M 4x0.7	-	4	8	21	16	6	8	8	0.5	0.005	
G 5x10	10 20 0005 0010	5	M 5x0.8	-	5	10	26	20	7.5	9	10	0.5	0.009	
G 6x12	10 20 0006 0012	6	M 6x1	-	6	12	31	24	9	10	12	0.5	0.015	
G 8x16	10 20 0008 0016	8	M 8x1.25	M 8x1	8	16	42	32	12	14	16	0.5	0.037	
	12 20 0008 0016													
G 10x20	10 20 0010 0020	10	M 10x1.5	M 10x1.25	10	20	52	40	15	18	20	0.5	0.074	
	14 20 0010 0020													
G 12x24	10 20 0012 0024	12	M 12x1.75	M 12x1.25	12	24	62	48	18	20	24	0.5	0.121	
	14 20 0012 0024													
G 14x28	10 20 0014 0028	14	M 14x2	M 14x1.5	14	27	72	56	22.5	24	28	1	0.178	
	16 20 0014 0028													
G 16x32	10 20 0016 0032	16	M 16x2	M 16x1.5	16	32	83	64	24	26	32	1	0.282	
	16 20 0016 0032													
G 20x40	10 20 0020 0040	20	M 20x2.5	M 20x1.5	20	40	105	80	30	34	40	1	0.55	
	16 20 0020 0040													

¹⁾ code for thread:
regular thread
regular thread, left-handed
fine-pitch thread
fine-pitch thread, left-handed

no code
LH
FG
FGLH

²⁾ for semifinished products, tolerance h11 according to DIN 178

09_01
01/2007

Retaining:

with folding spring bolts hardened (mbo catalog section 2) or
with bolts hardened (mbo catalog section 4) and
retainers (mbo catalog section 13) or washer and cotter pin;
also see clevis joint combinations
(mbo catalog section 11)

Material:

1.0718 (11SMnPb30+C)

hardness: 60±2 HRC

hardening depth: at least 0.3 mm

Surface protection:

polished, oiled or at manufacturer's choice
optional: phosphatized and oiled, electroplated,
galvanized, passivated in white-blue
(silver/clear) or yellow

Special version:

left-handed and other threads or special slot widths
"b" and transversal hole upon request; please send
us your inquiry