



The Carstick® concept combines LF 3000® one-piece cartridges with a specially designed protection and dispensing sleeve. Ideal for continuous processes in large quantities, it provides a high performance solution for automatic, semi automatic and manual assembly equipment for pneumatic components.

Advantages :

- **assembly time saving, with complete safety**
 - one piece cartridge, no risk of losing the seal
 - pre-greased and protected seal
 - self-centring of the cartridge to half of its height within the cavity
 - protection against contaminants (dust, swarf ...)
- **Tried and tested technology**
 - LF 3000® technical performance
 - automatic seal, full flow, vacuum capability.
- **optimised dimensions**
- **suitable for automatic processes**
 - automatic self alignment during insertion
 - capable of combining dispensing and assembly
- **closer mounting tolerances and shallow cavities**

working specifications

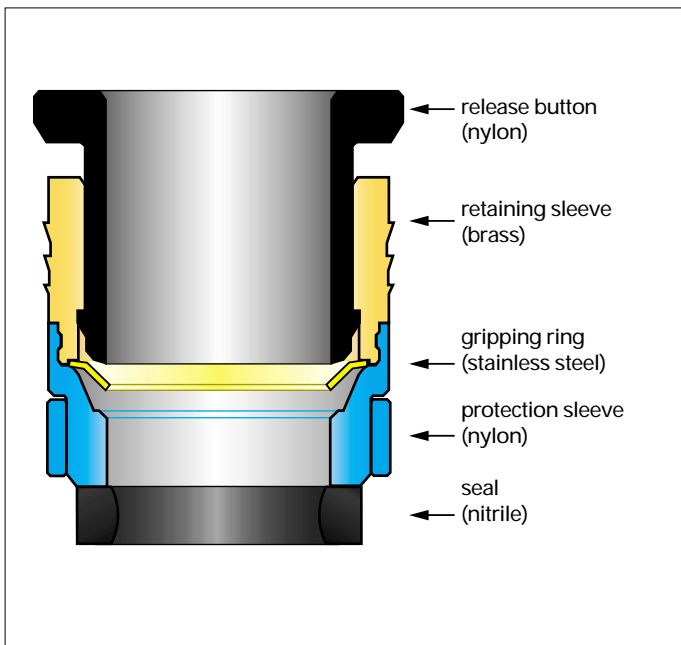

suitable fluid	compressed air			
working pressure	20 bar maximum			
working temperature	-20°C to +80°C			
vacuum	755 mm Hg (99% vacuum)			
Force required for insertion (F)	tube Ø	nylon cavity	aluminium cavity	brass cavity
	4 mm	300 daN	300 daN	300 daN
	6 mm	300 daN	300 daN	300 daN
	8 mm	300 daN	350 daN	300 daN
	10 mm	300 daN	300 daN	300 daN
	12 mm	400 daN	400 daN	400 daN

Carstick® is designed for use with Legris semi-rigid nylon and flexible polyurethane tubing.

Legris can also provide alternative designs such as :

- other types of seal (EPDM, FKM...)
- other materials (stainless steel sleeve...)

Please ask for details.

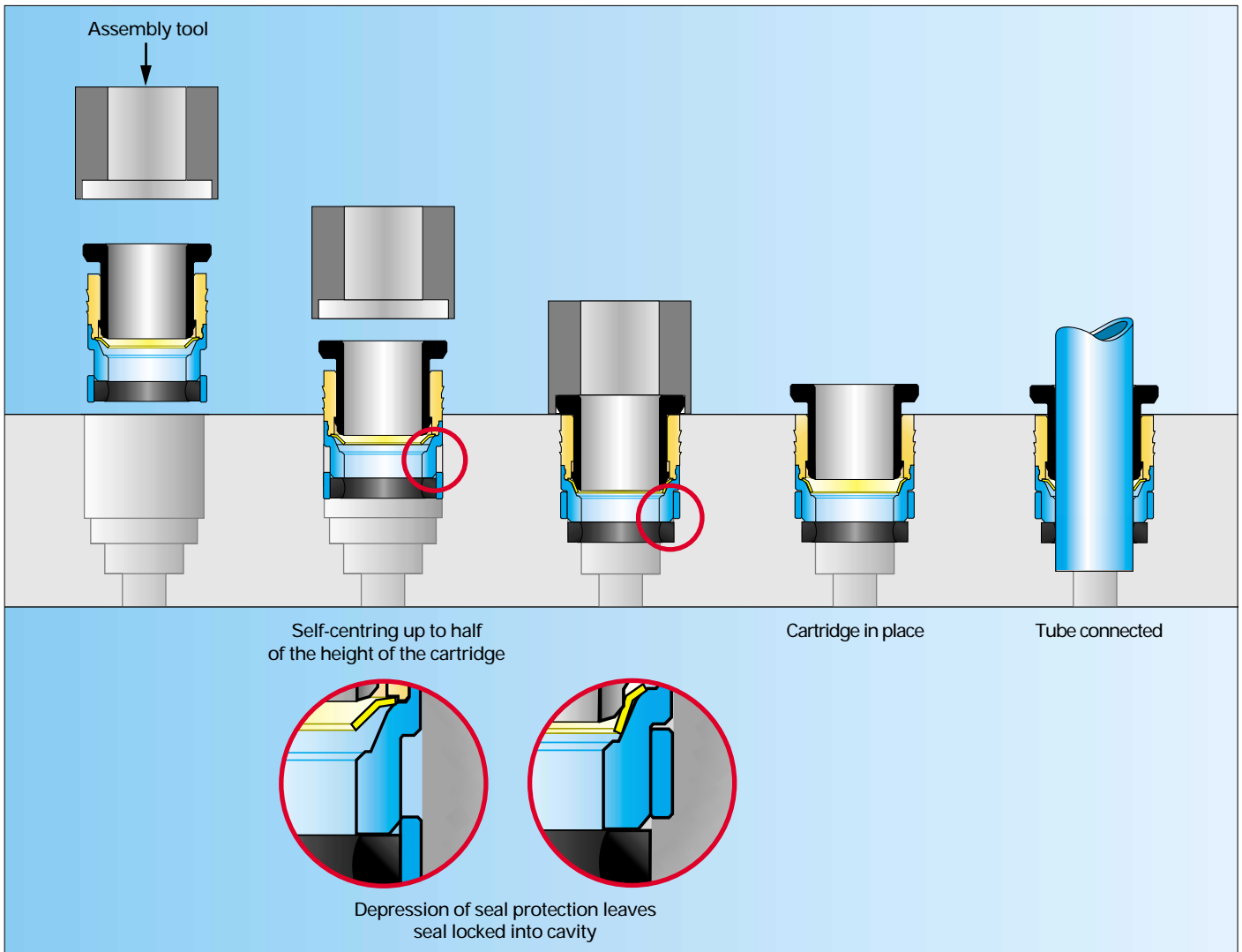

cartridge

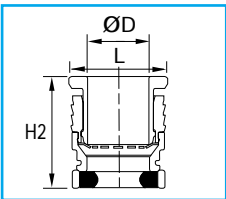

ØD	L	H2
4	8,1	10
6	10,1	11,5
8	13	15
10	15,5	17
12	19,5	19,5

cavity dimensions

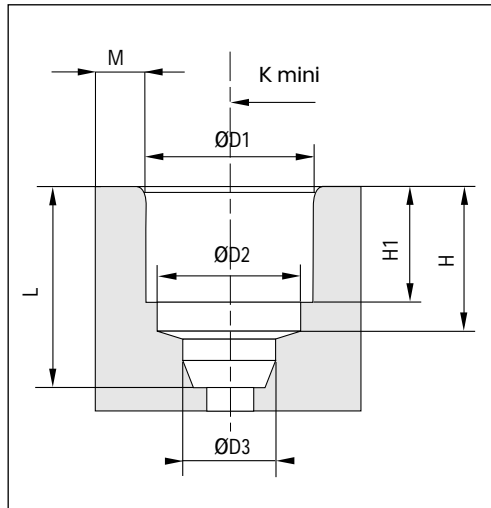

ØD	ØD3	H	H1	L
4	4,1	8,15	6	10
6	6,1	9,65	7,5	12
8	8,15	12,45	9,9	15,5
10	10,15	14,35	11,7	19
12	12,17	16,75	13,9	22

nylon cavity					aluminium cavity				brass cavity			
ØD	ØD1	ØD2	K	M	ØD1	ØD2	K	M	ØD1	ØD2	K	M
4	8,25	7,05	9,8	1,5	8,25	7,05	11,5	3	8,25	7,05	10,25	2
6	10,2	9,15	12,2	2	10,3	9,15	13,5	3	10,25	9,1	12,25	2
8	12,15	10,85	14,2	2	12,2	10,85	15,2	3	12,2	10,85	14,25	2
10	14,8	13,2	16,8	2	15,05	13,2	17,1	2	15,05	13,2	17,1	2
12	17,5	15,5	20	2,5	17,5	15,5	20	2,5	17,65	15,5	20	2,5

Please consult us for detailed drawings of cavity dimensions and tolerances.

3100 carstick®

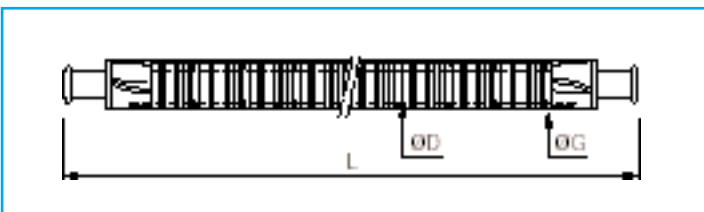

ØD cartridge		G	L
4	3100 04 00	10,3	554
6	3100 06 00	14,5	629
8	3100 08 00	15,25	794
10	3100 10 00	19,5	930
12	3100 12 00	21,3	1038

50 cartridges per Carstick®