

SSP TYPE

– Cylindrical Spline Nut –

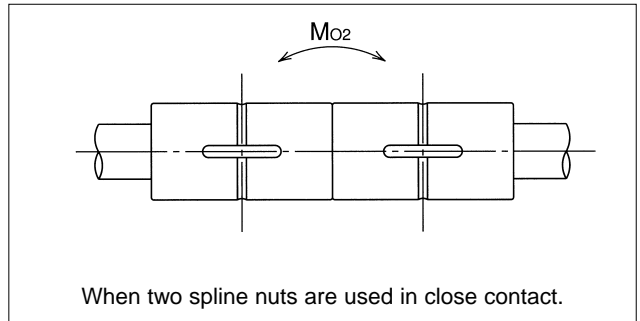

part number	major dimensions											
	D		L		B	b		t +0.05 0 mm	L ₁	d	Ds	
	mm	tolerance μm	mm	tolerance mm		mm	tolerance μm				mm	mm
SSP 4	10	0/-9	16	0 -0.2	-	2	+14 0	1.2	6	-	4	0
SSP 6	14	0	25			2.5		1.2	10.5	1	6	-12
SSP 8	16	-11	25			2.5		1.2	10.5	1.5	8	0
SSP 10	21	0	33			3		1.5	13	1.5	10	-15
SSP 13A	24	-13	36			3		1.5	15	1.5	13	0
SSP 16A	31		50			3.5		2	17.5	2	16	-18
SSP 20	32	0	60	0 -0.3	-	4	+18 0	2.5	26	2	18.2	0 -21
SSP 25	37	-16	70			5	3	33	3	23		
SSP 30	45		80			7	4	41	3	28		
SSP 40	60	0	100			10	4.5	55	4	37.4	0	
SSP 50	75	-19	112			15	5	60	4	47	-25	
SSP 60	90		127			18	6	68	4	56.5	0 -30	
SSP 80	120	0 -22	160	118.2	6	76	5	80				
SSP 80L		217	175.2	160								
SSP100	150	0	185	132.6	20	+33 0	7	110	5	100	0 -35	
SSP100L		-25	248	195.6				160				

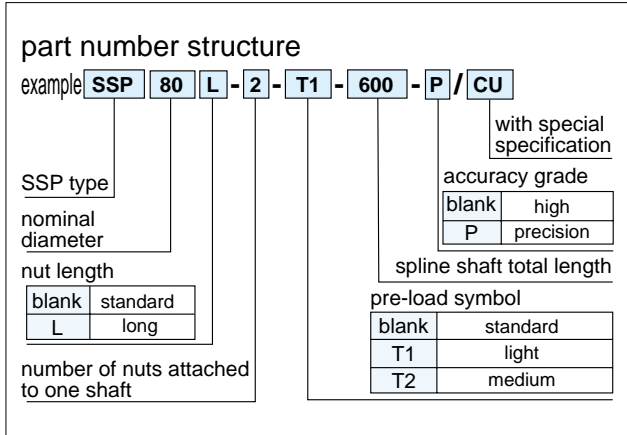
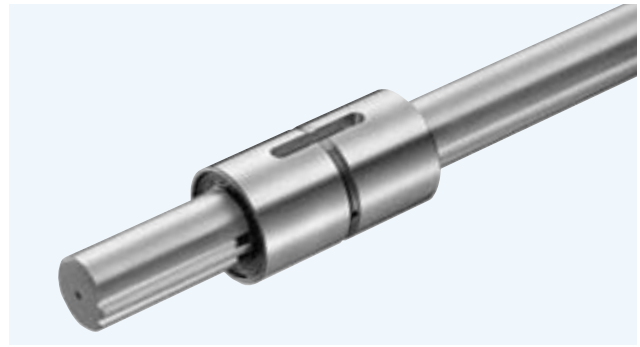
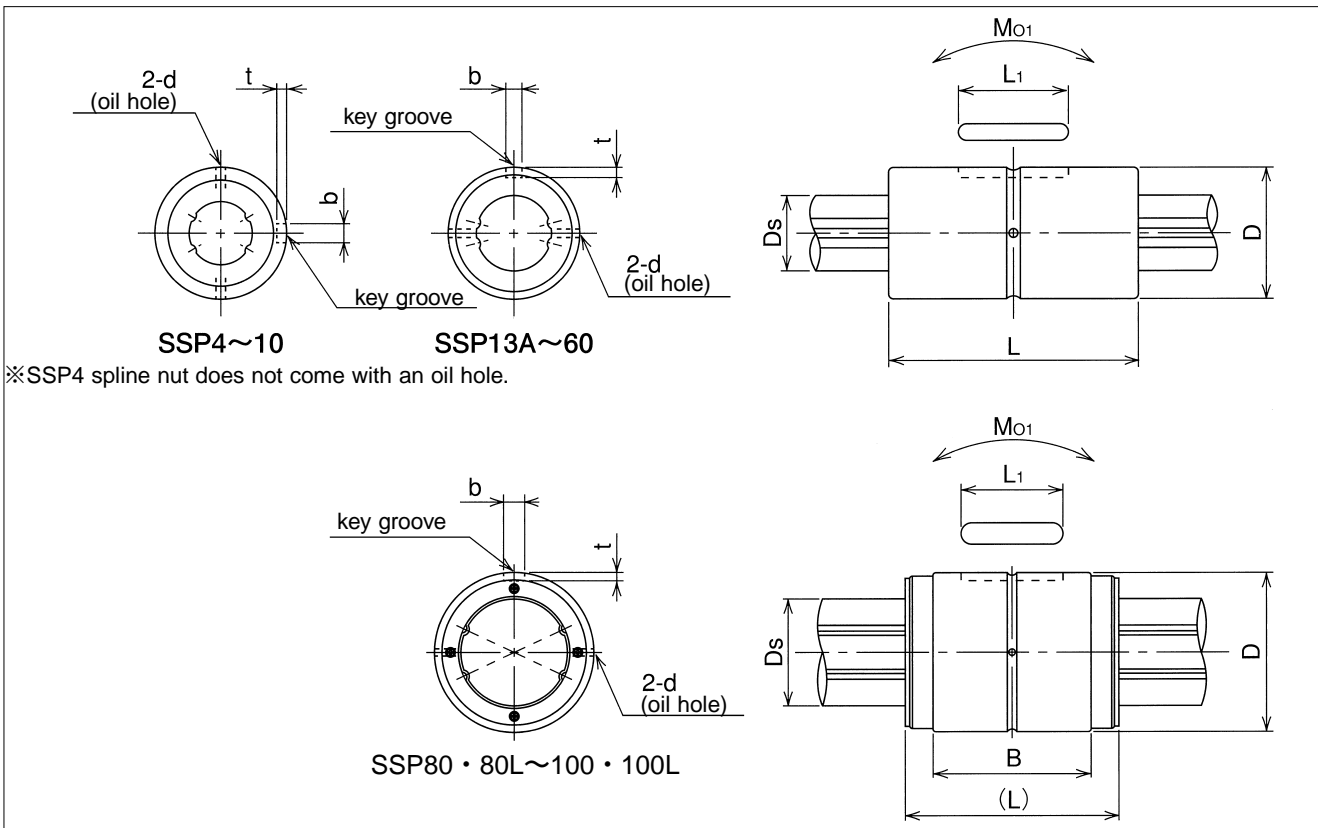

basic torque rating		basic load rating		allowable static moment		second cross-sectional moment of inertia	cross-sectional coefficient	mass		part number
dynamic C _T N · m	static C _{0T} N · m	dynamic C kN	static C ₀ kN	M ₀₁ N · m	M ₀₂ N · m			nut kg	shaft kg/m	
0.74	1.05	0.86	1.22	1.97	10.3	1.18 × 10	5.90	0.0065	0.10	SSP 4
1.5	2.4	1.22	2.28	5.1	40	5.9 × 10	1.97 × 10	0.019	0.21	SSP 6
2.1	3.7	1.45	2.87	7.4	50	1.9 × 10 ²	4.76 × 10	0.023	0.38	SSP 8
4.4	8.2	2.73	5.07	18.0	116	4.61 × 10 ²	9.22 × 10	0.054	0.60	SSP 10
21	39.2	2.67	4.89	13.7	109	1.38 × 10 ³	2.13 × 10 ²	0.07	1.0	SSP 13A
60	110	6.12	11.2	46	299	2.98 × 10 ³	3.73 × 10 ²	0.15	1.5	SSP 16A
83	133	7.84	11.3	63	500	5.05 × 10 ³	5.54 × 10 ²	0.20	2.0	SSP 20
162	239	12.3	16.1	104	830	1.27 × 10 ⁴	1.11 × 10 ³	0.22	3.1	SSP 25
289	412	18.6	23.2	181	1,470	2.75 × 10 ⁴	1.96 × 10 ³	0.35	4.8	SSP 30
637	882	30.8	37.5	358	2,940	8.73 × 10 ⁴	4.67 × 10 ³	0.81	8.6	SSP 40
1,390	3,180	46.1	74.2	696	4,400	2.16 × 10 ⁵	9.21 × 10 ³	1.5	13.1	SSP 50
2,100	4,800	58.0	127	1,300	8,800	4.51 × 10 ⁵	1.60 × 10 ⁴	2.5	19	SSP 60
3,860	6,230	83.1	134	2,000	11,100	1.93 × 10 ⁶	4.38 × 10 ⁵	5.1	39	SSP 80
5,120	9,340	110	201	4,410	21,100			7.6		SSP 80L
6,750	11,570	135	199	3,360	19,300	4.69 × 10 ⁶	9.38 × 10 ⁵	9.7	61	SSP100
8,960	17,300	179	298	7,340	37,700			13.9		SSP100L

1kN ≒ 102kgf 1N · m ≒ 0.102kgf · m

SSPM TYPE

– Keyless Spline Nut –

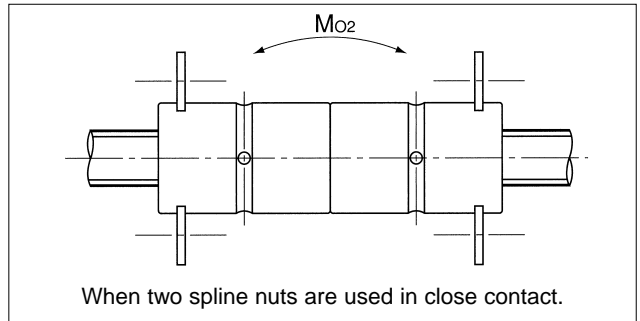
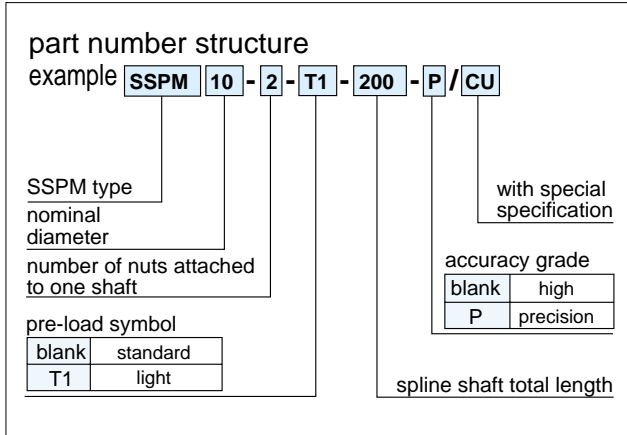
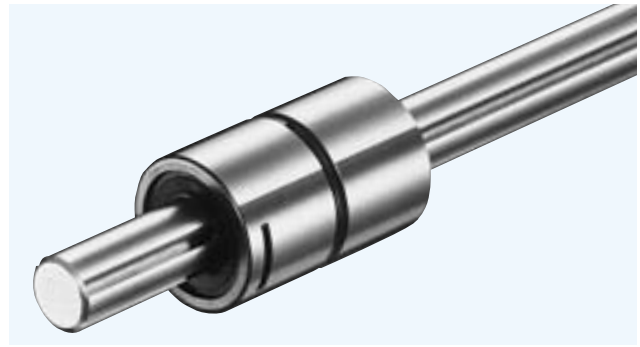

part number	major dimensions												
	D		L		F	W	C	A	d	B	H	K	G
	mm	tolerance μm	mm	tolerance mm									
SSPM 6	14	0	25	0	2.2	1.1	1.0	12.0	1	9.4	25.6	6.8	2.9
SSPM 8	16	-11	25	-0.2	2.7	1.3	1.2	13.6	1.5	11	30.6	8.5	3.5
SSPM10	21	0/-13	33		2.7	1.3	1.2	18.6	1.5	13.5	35.6	8.5	3.5

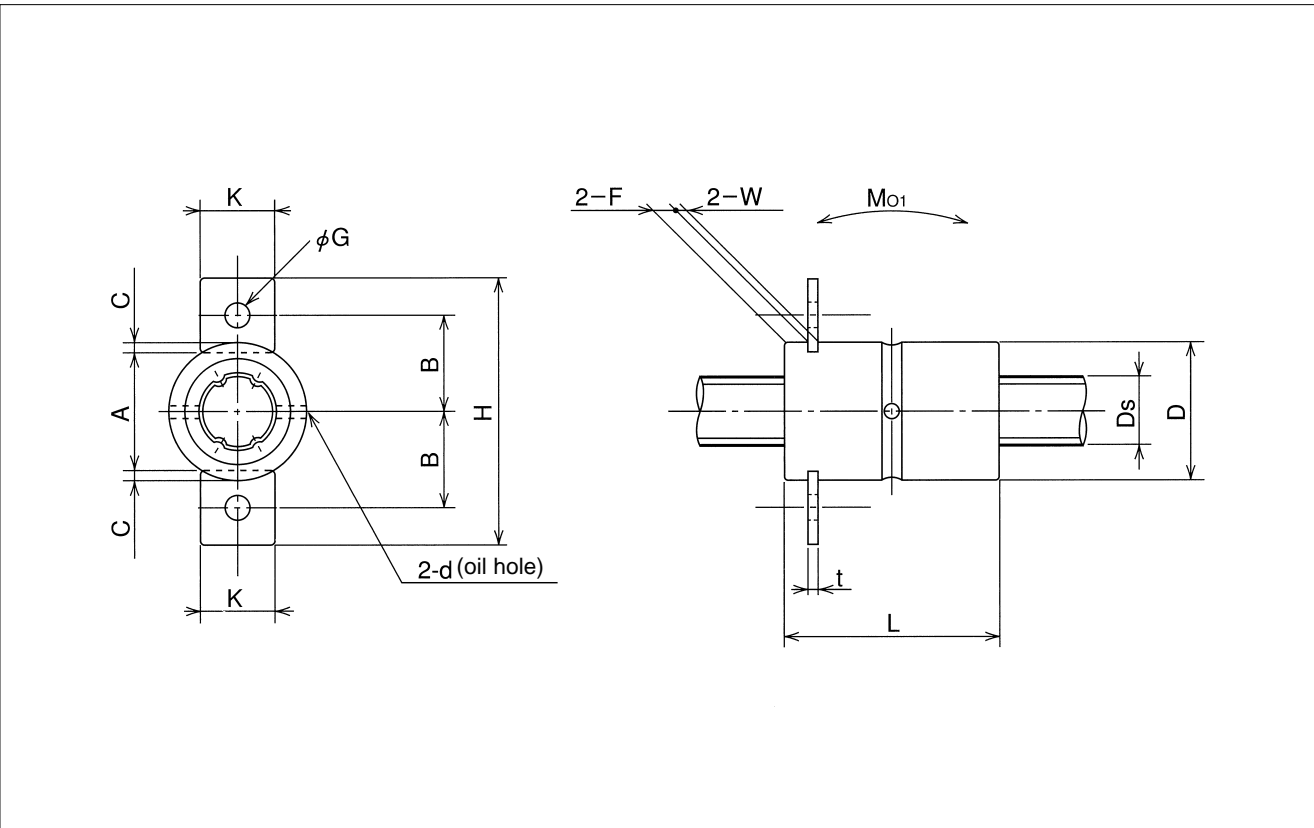

t	Ds	tolerance μm	basic torque rating		basic load rating		allowable static moment		second cross-sectional moment of inertia mm ⁴	cross-sectional coefficient mm ³	mass		part number
			dynamic	static	dynamic	static	M01	M02			nut	shaft	
			C _T	C _{0T}	C	C ₀	N · m	N · m			kg	kg/m	
1.0	6	0/-12	1.5	2.4	1.22	2.28	5.1	40	59	19.7	0.019	0.21	SSPM 6
1.2	8	0	2.1	3.7	1.45	2.87	7.4	50	190	47.6	0.023	0.38	SSPM 8
1.2	10	-15	4.4	8.2	2.73	5.07	18.0	116	461	92.2	0.054	0.60	SSPM10

1kN ≅ 102kgf 1N · m ≅ 0.102kgf · m

SSPF TYPE

– Flange Type Nut –

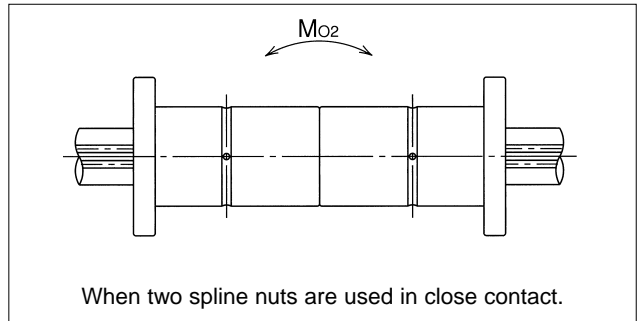
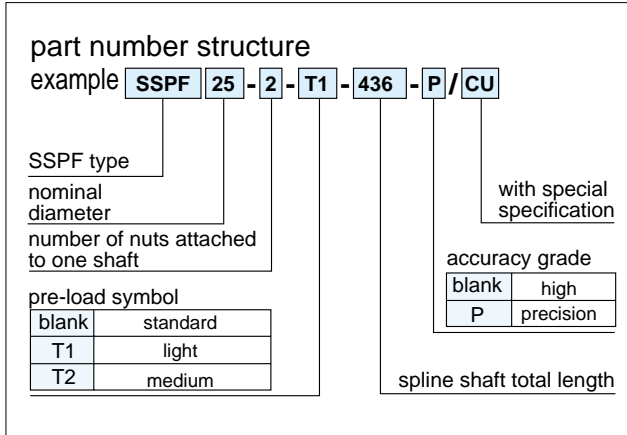
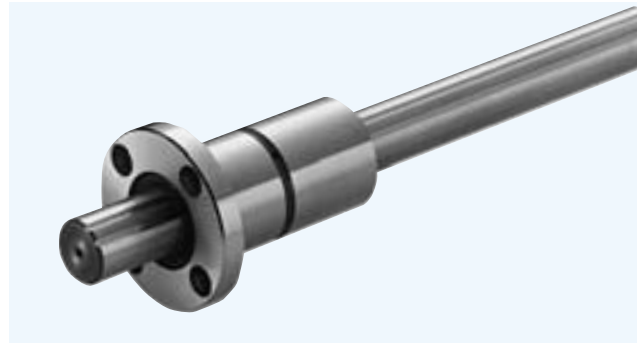

part number	major dimensions									
	D		L		Df	H	P.C.D.	d ₁ × d ₂ × h	W	d
	mm	tolerance μm	mm	tolerance mm						
SSPF 6	14	0	25	0 -0.2	30	5	22	3.4 × 6.5 × 3.3	7.5	1
SSPF 8	16	-11	25		32	5	24	3.4 × 6.5 × 3.3	7.5	1.5
SSPF10	21	0	33		42	6	32	4.5 × 8 × 4.4	10.5	1.5
SSPF13A	24	-13	36		43	7	33	4.5 × 8 × 4.4	11	1.5
SSPF16A	31	0	50		50	7	40	4.5 × 8 × 4.4	18	2
SSPF20	32		60	51	7	40	4.5 × 8 × 4.4	23	2	
SSPF25	37		-16	70	60	9	47	5.5 × 9.5 × 5.4	26	3
SSPF30	45	0 -0.3	80	70	10	54	6.6 × 11 × 6.5	30	3	
SSPF40	60		100	90	14	72	9 × 14 × 8.6	36	4	
SSPF50	75		-19	112	113	16	91	11 × 17.5 × 11	40	4
SSPF60	90		0/-22	127	129	18	107	11 × 17.5 × 11	45.5	4

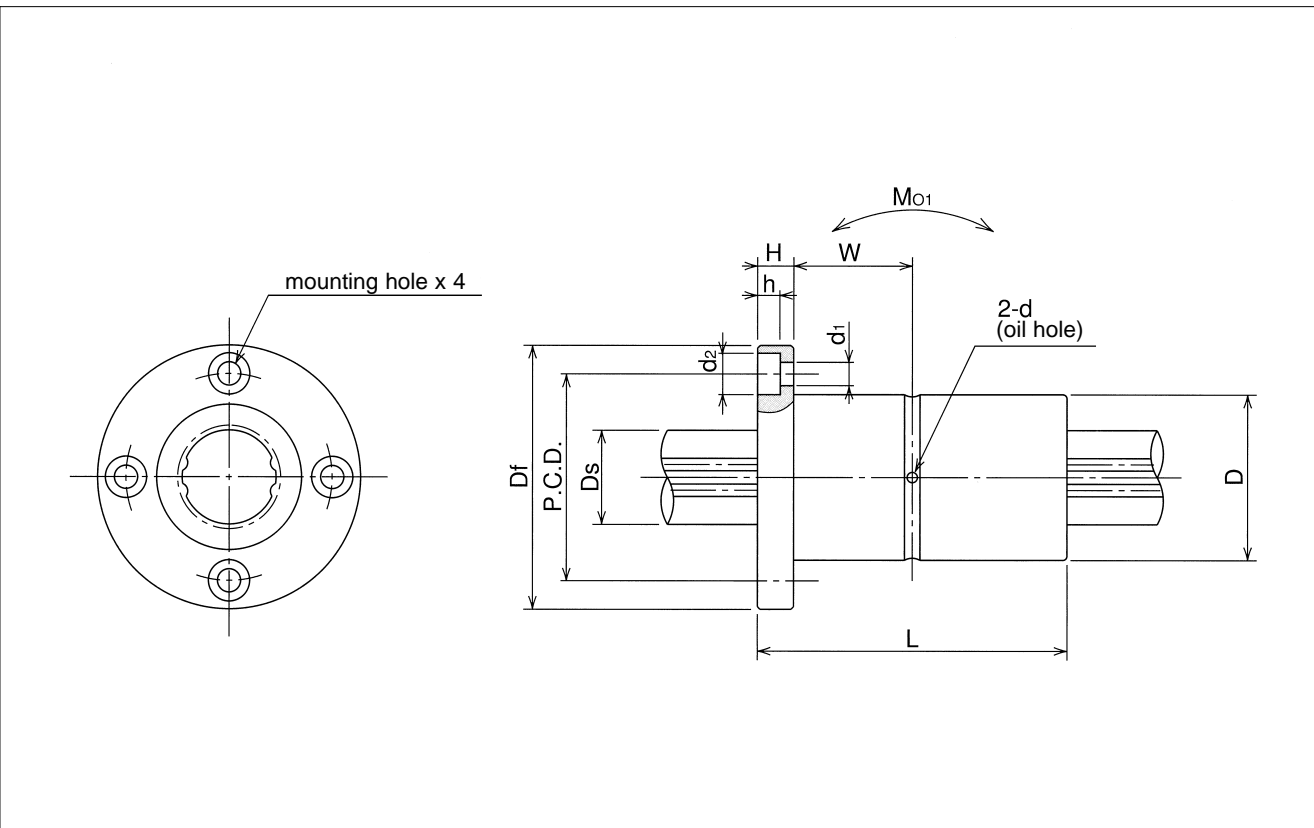

D _s mm	tolerance μm	basic torque rating		basic load rating		allowable static moment		second cross-sectional moment of inertia mm ⁴	cross-sectional coefficient mm ³	mass		part number
		dynamic C _T N·m	static C _{0T} N·m	dynamic C kN	static C ₀ kN	M ₀₁ N·m	M ₀₂ N·m			nut kg	shaft kg/m	
		6	0/-12	1.5	2.4	1.22	2.28			5.1	40	
8	0	2.1	3.7	1.45	2.87	7.4	50	190	47.6	0.042	0.38	SSPF 8
10	-15	4.4	8.2	2.73	5.07	18.0	116	461	92.2	0.094	0.6	SSPF10
13	0	21	39.2	2.67	4.89	13.7	109	1,380	213	0.1	1	SSPF13A
16	-18	60	110	6.12	11.2	46	299	2,980	373	0.2	1.5	SSPF16A
18.2	0	83	133	7.84	11.3	63	500	5,050	554	0.22	2	SSPF20
23	-21	162	239	12.3	16.1	104	830	12,700	1,110	0.32	3.1	SSPF25
28	0	289	412	18.6	23.2	181	1,470	27,500	1,960	0.51	4.8	SSPF30
37.4	-25	637	882	30.8	37.5	358	2,940	87,300	4,670	1.15	8.6	SSPF40
47	0	1,390	3,180	46.1	74.2	696	4,400	216,000	9,210	2.1	13.1	SSPF50
56.5	0/-30	2,100	4,800	58.0	127	1,300	8,800	451,000	16,000	3.3	19	SSPF60

1kN ≅ 102kgf 1N·m ≅ 0.102kgf·m

SSPT TYPE

– Two Side Cut Flange Type –

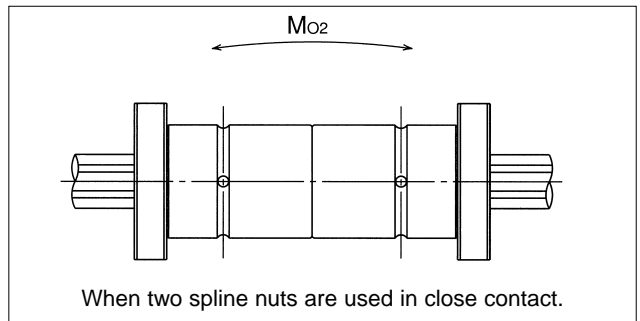
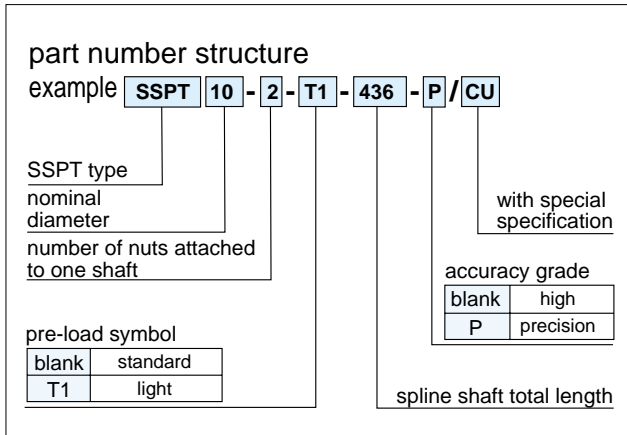
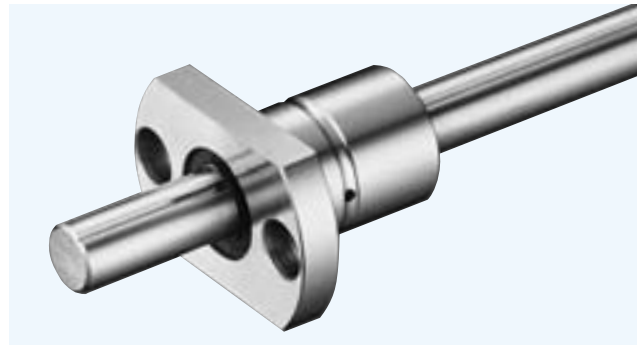

part number	major dimensions										
	D		L		Df	B	H	P.C.D.	d ₁ × d ₂ × h	W	d
	mm	tolerance μm	mm	tolerance mm							
SSPT 6	14	0	25	0 -0.2	30	18	5	22	3.4 × 6.5 × 3.3	7.5	1
SSPT 8	16	-11	25		32	21	5	24	3.4 × 6.5 × 3.3	7.5	1.5
SSPT10	21	0/-13	33		42	25	6	32	4.5 × 8 × 4.4	10.5	1.5

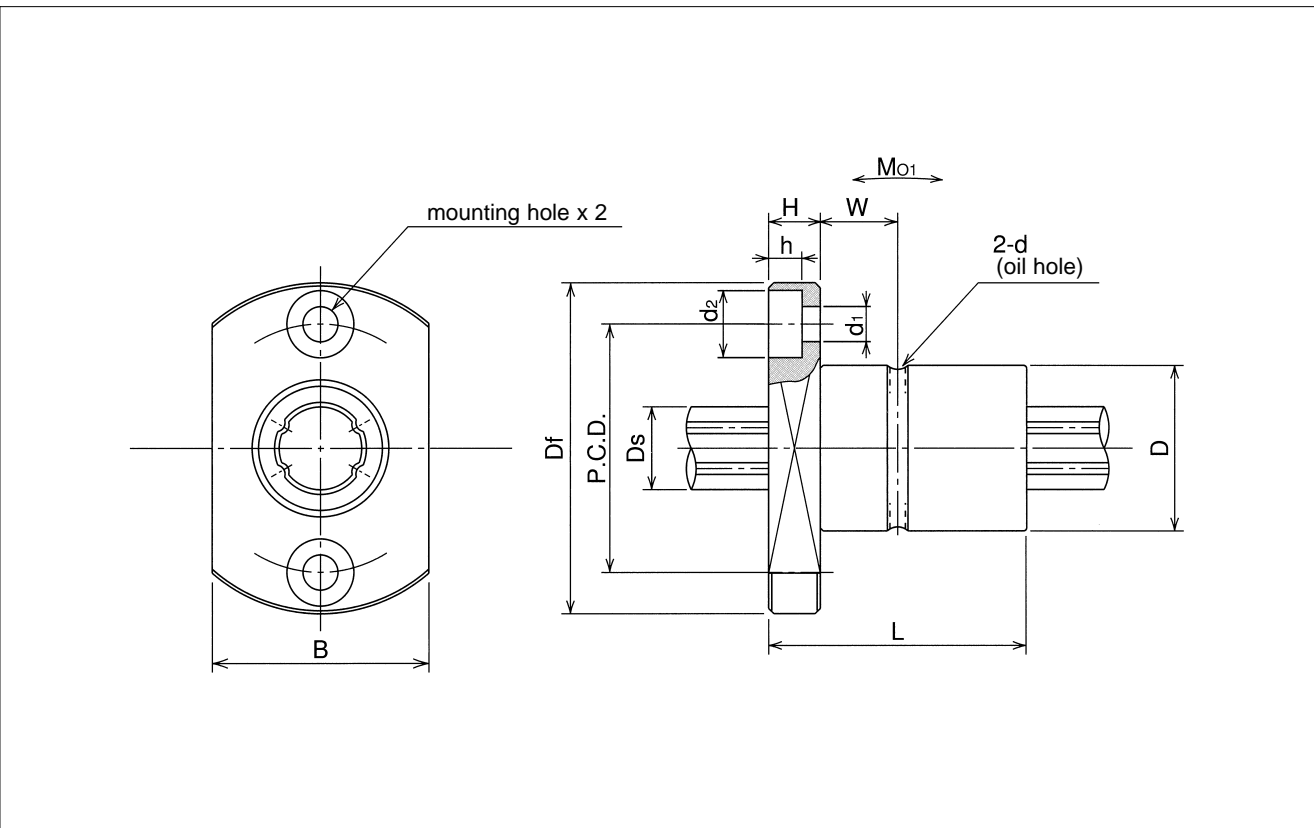

mm	D_s tolerance μm	basic torque rating		basic load rating		allowable static moment		second cross-sectional moment of inertia mm^4	cross-sectional coefficient mm^3	mass		part number
		dynamic	static	dynamic	static	M_{01} $N \cdot m$	M_{02} $N \cdot m$			nut kg	shaft kg/m	
		C_T $N \cdot m$	C_{0T} $N \cdot m$	C kN	C_o kN							
6	0/-12	1.5	2.4	1.22	2.28	5.1	40	59	19.7	0.029	0.21	SSPT 6
8	0	2.1	3.7	1.45	2.87	7.4	50	190	47.6	0.035	0.38	SSPT 8
10	-15	4.4	8.2	2.73	5.07	18.0	116	461	92.2	0.075	0.6	SSPT10

1kN \approx 102kgf 1N \cdot m \approx 0.102kgf \cdot m

SPA TYPE

– Keyless Block Type –

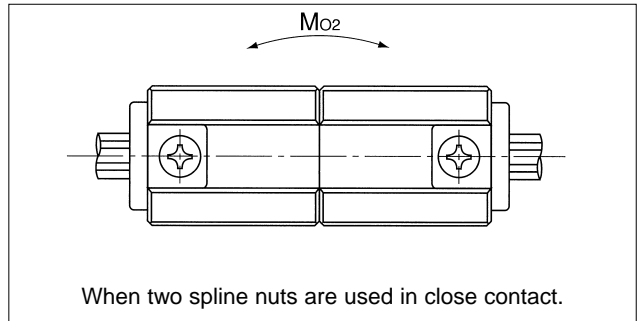
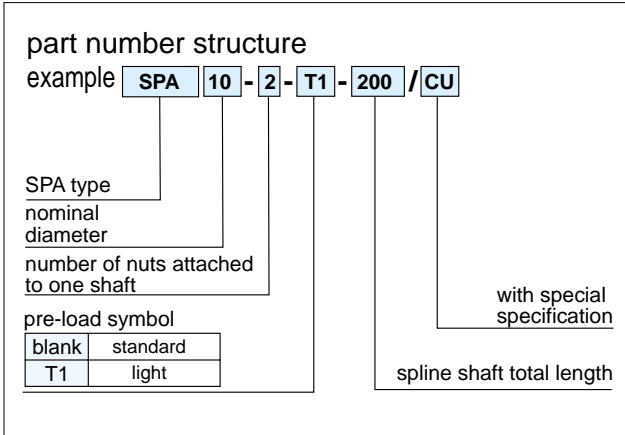
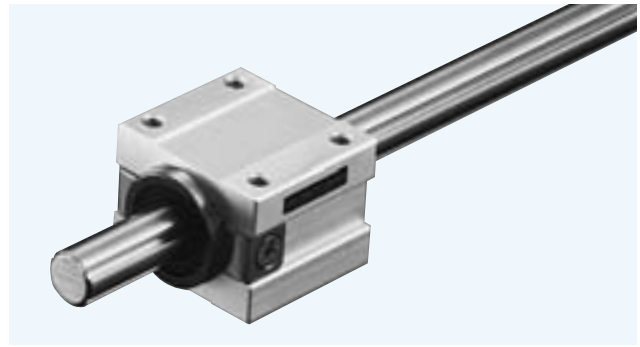

part number	major dimensions											
	h	E	W	L	F	L ₁	T	B	C	S	ℓ	D
	mm	mm	mm	mm	mm	mm	mm	mm	mm		mm	mm
SPA 6	9	12.5	25	25	18	22.5	4.2	18	16	M3	5	14
SPA 8	10	14	28	25	20	22	5	20	16	M3	5	16
SPA10	12.5	16.5	33	33	25	30	7.5	25	20	M4	6	21

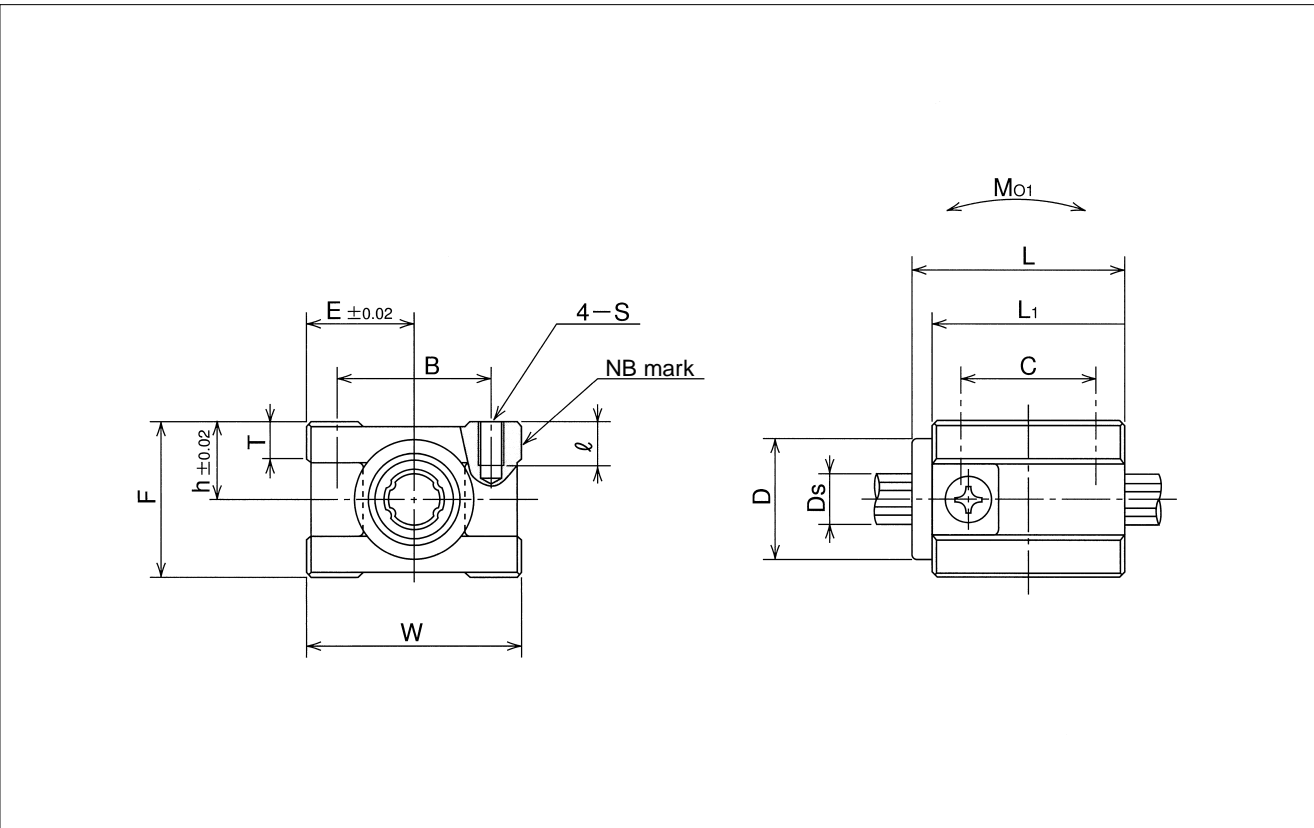

Ds		basic torque rating		basic load rating		allowable static moment		second cross-sectional moment of inertia	cross-sectional coefficient	mass		part number
		dynamic	static	dynamic	static	M01	M02			nut	shaft	
		C _T	C _{0T}	C	C ₀							
mm	tolerance μm	N · m	N · m	kN	kN	N · m	N · m	mm ⁴	mm ³			
6	0/-12	1.5	2.4	1.22	2.28	5.1	40	59	19.7	0.035	0.21	SPA 6
8	0	2.1	3.7	1.45	2.87	7.4	50	190	47.6	0.042	0.38	SPA 8
10	-15	4.4	8.2	2.73	5.07	18	116	461	92.2	0.088	0.6	SPA10

1kN ≅ 102kgf 1N · m ≅ 0.102kgf · m

SPA-W TYPE

— Keyless Block Double Type —

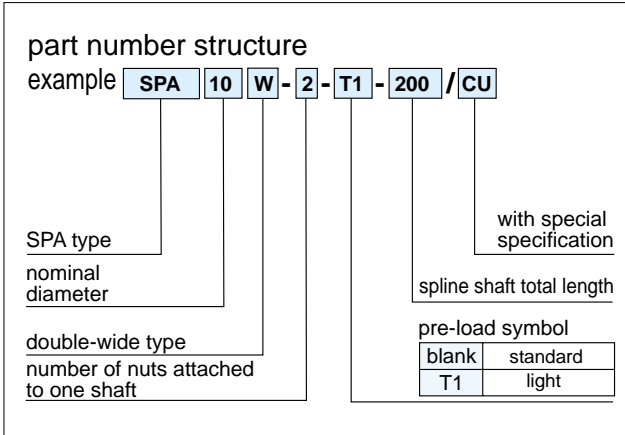
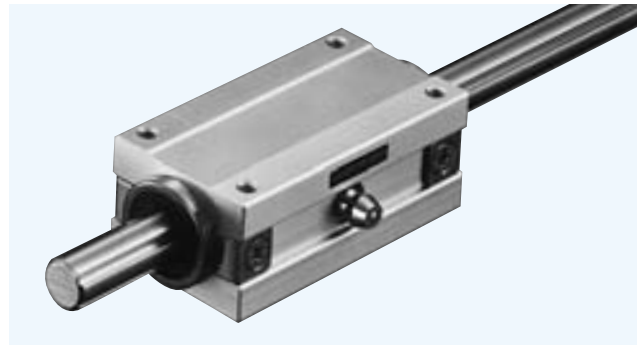

part number	major dimensions											
	h	E	W	L	F	L ₁	T	Gw	B	C	S	ℓ
	mm	mm	mm	mm	mm	mm	mm	mm	mm	mm		mm
SPA 6W	9	12.5	25	50	18	45	4.2	6.5	18	35	M3	5
SPA 8W	10	14	28	50	20	44	5		20	34	M3	5
SPA10W	12.5	16.5	33	66	25	60	7.5		25	50	M4	6

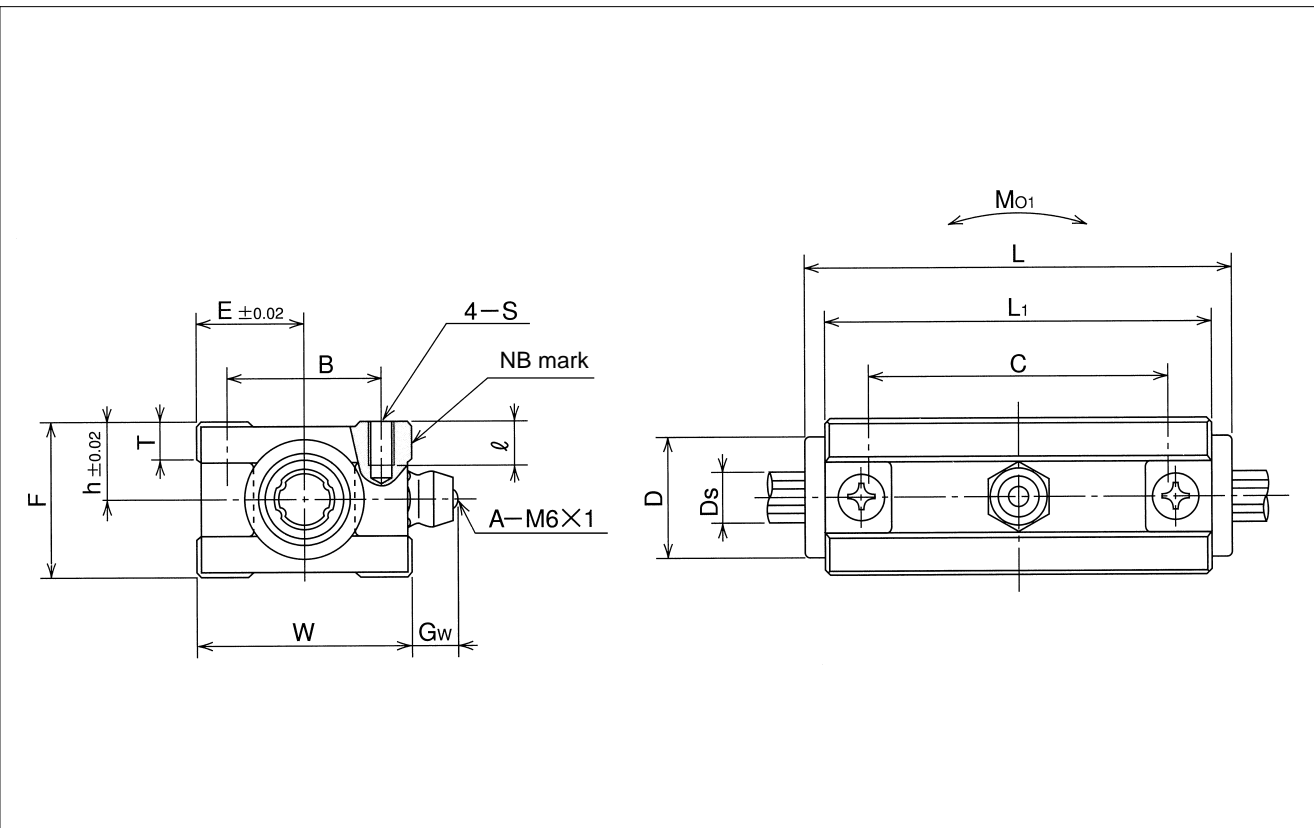

D mm	Ds mm	tolerance μm	basic torque rating		basic load rating		allowable static moment Mo1 N · m	second cross- sectional moment of inertia mm ⁴	cross- sectional coefficient mm ³	mass		part number
			dynamic CT N · m	static COT N · m	dynamic C kN	static Co kN				nut kg	shaft kg/m	
			14	6	0/-12	3.0				4.8	1.98	
16	8	0	4.2	7.4	2.35	5.78	50	190	47.6	0.085	0.38	SPA 8W
21	10	-15	8.8	16.4	4.42	10.14	116	461	92.2	0.179	0.60	SPA10W

1kN ≒ 102kgf 1N · m ≒ 0.102kgf · m

SSPB TYPE

– Block Type –

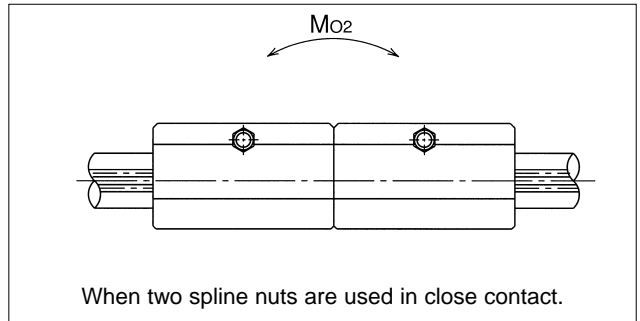
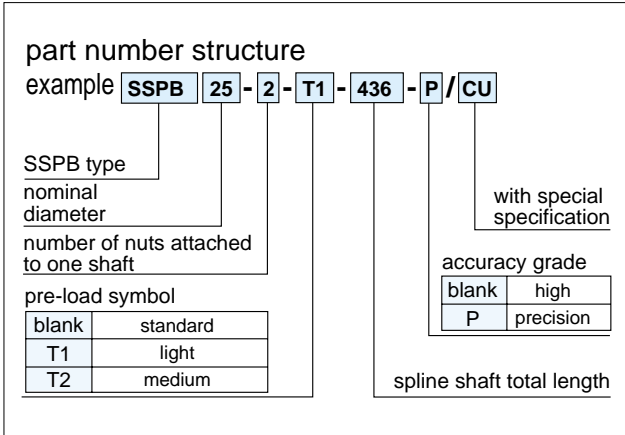
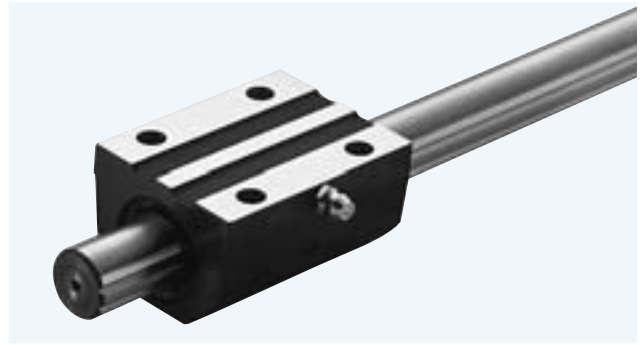

part number	major dimensions										
	h	B	L	E	b	T	P ₁	P ₂	S	ℓ	T ₁
	mm	mm	mm	mm	mm	mm	mm	mm		mm	mm
SSPB20	19	48	60	24	35	8	35	35	M 6	12	5.5
SSPB25	22	60	70	30	41.5	10	40	40	M 8	12	6
SSPB30	26	70	80	35	50	12	50	50	M 8	12	7
SSPB40	32	86	100	43	63	15	60	60	M10	15	8

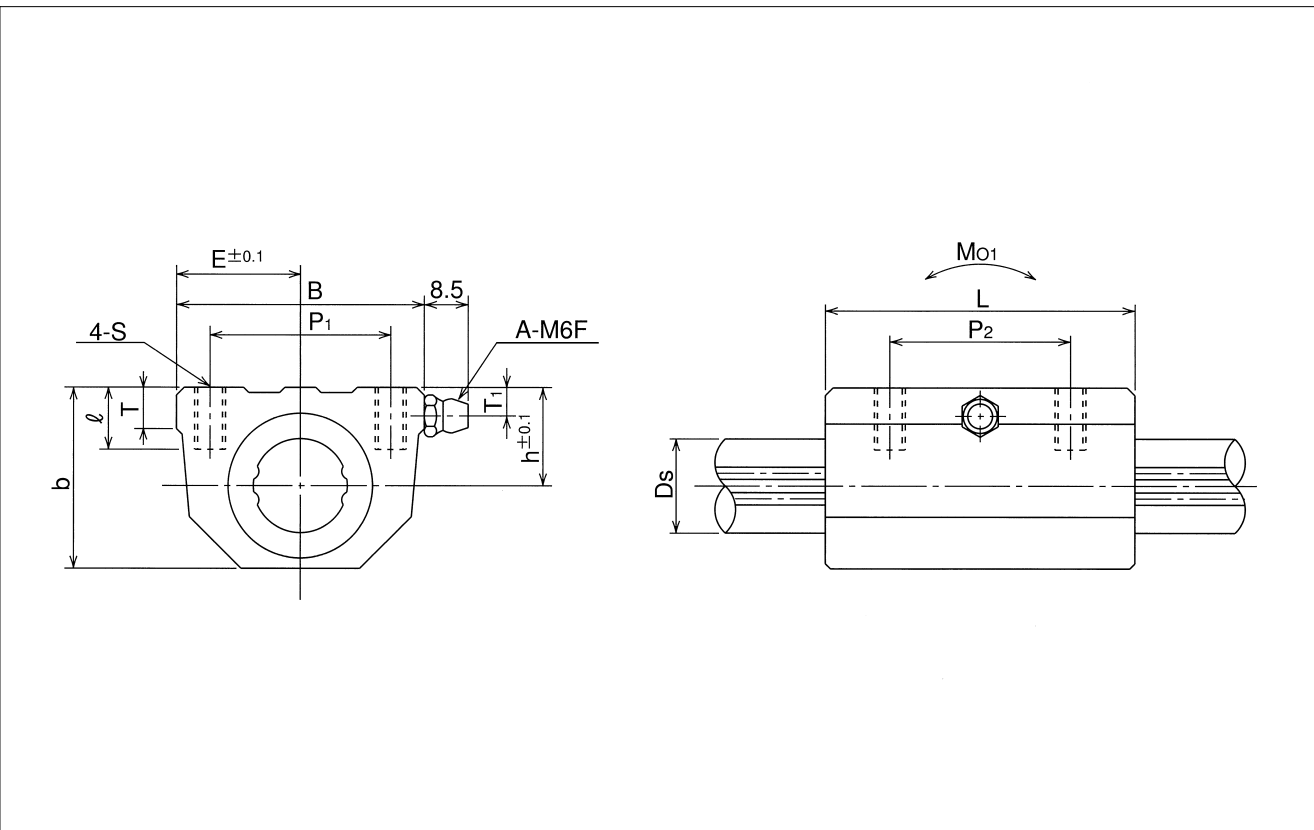

Ds		basic torque rating		basic load rating		allowable static moment		second cross-sectional moment of inertia	cross-sectional coefficient	mass		part number
		dynamic	static	dynamic	static	M ₀₁	M ₀₂			nut	shaft	
		C _T	C _{0T}	C	C ₀							
mm	tolerance μm	N · m	N · m	kN	kN	N · m	N · m	mm ⁴	mm ³			
18.2	0 -21	83	133	7.84	11.3	63	500	5,050	554	0.55	2.0	SSPB20
23		162	239	12.3	16.1	104	830	12,700	1,110	0.9	3.1	SSPB25
28		289	412	18.6	23.2	181	1,470	27,500	1,960	1.4	4.8	SSPB30
37.4	0/-25	637	882	30.8	37.5	358	2,940	87,300	4,670	2.5	8.6	SSPB40

1kN ≙ 102kgf 1N · m ≙ 0.102kgf · m

STANDARD BALL SPLINE

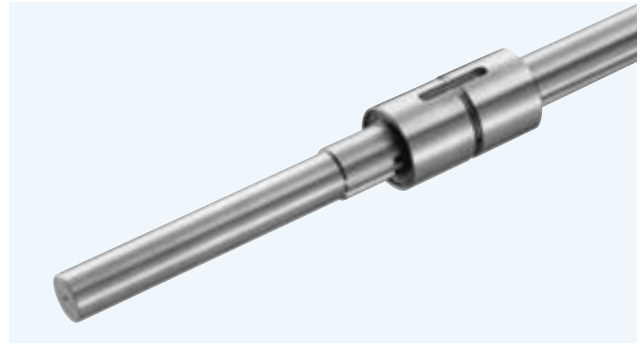

part number structure
example **SPA 10 W S - 2 - T1 - 400**

nut shape		standard length L	
SSP	cylindrical type	blank	standard
SSPM	key less type	T1	light
SSPF	flange type	T2	medium
SSPT	two side cut flange type	number of nuts attached to one shaft	
SPA	aluminum block type	standard spline shaft	
SSPB	block type	double-wide type	
nominal diameter			

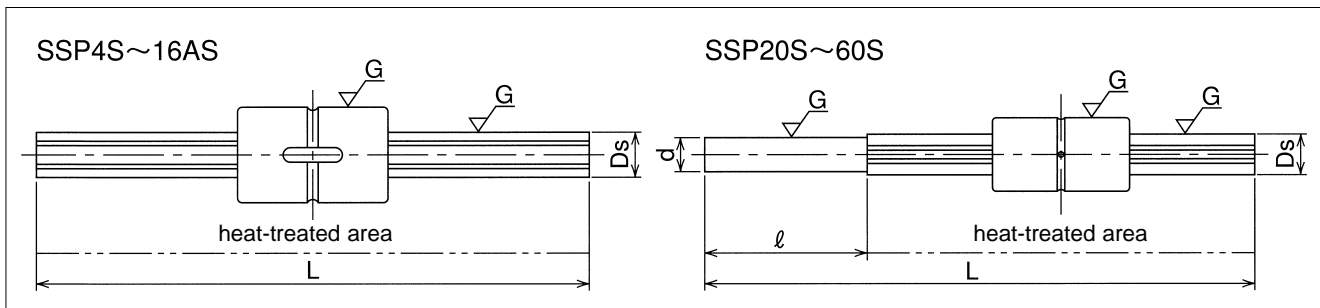

nominal diameter	major dimensions										applicable nut							
	Ds		d		ℓ	standard length L					SSP	SSPM	SSPF	SSPT	SPA	SPA-W	SSPB	
	mm	tolerance μm	mm	tolerance μm		mm												
4	4	0	-	-	-	100	150	200	300	-	○	-	-	-	-	-	-	
6	6	-12	-	-	-	150	200	300	400	-	○	○	○	○	○	○	-	
8	8	0	-	-	-	150	200	300	400	500	○	○	○	○	○	○	-	
10	10	-15	-	-	-	200	300	400	500	600	○	○	○	○	○	○	-	
13A	13	0	-	-	-	200	300	400	500	600	○	-	○	-	-	-	-	
16A	16	-18	-	-	-	200	300	400	500	600	○	-	○	-	-	-	-	
20	18.2	0	15	0/-18	150	350	450	550	650	-	○	-	○	-	-	-	○	
25	23		20	0	150	350	450	550	650	850	○	-	○	-	-	-	○	
30	28	-21	25		-21	150	450	550	650	750	1,150	○	-	○	-	-	-	○
40	37.4	0	30	150		550	750	950	1,150	-	○	-	○	-	-	-	○	
50	47	-25	40	0	150	650	850	1,150	1,350	-	○	-	○	-	-	-	-	
60	56.5	0/-30	45	-25	150	650	850	1,150	1,350	-	○	-	○	-	-	-	-	

Tolerance for length L for nominal diameter sizes 4-16A: JIS B0405 coarse grade.

○ yes - no

Refer to dimension tables for nut shape and dimensions.

COMMERCIAL BALL SPLINE

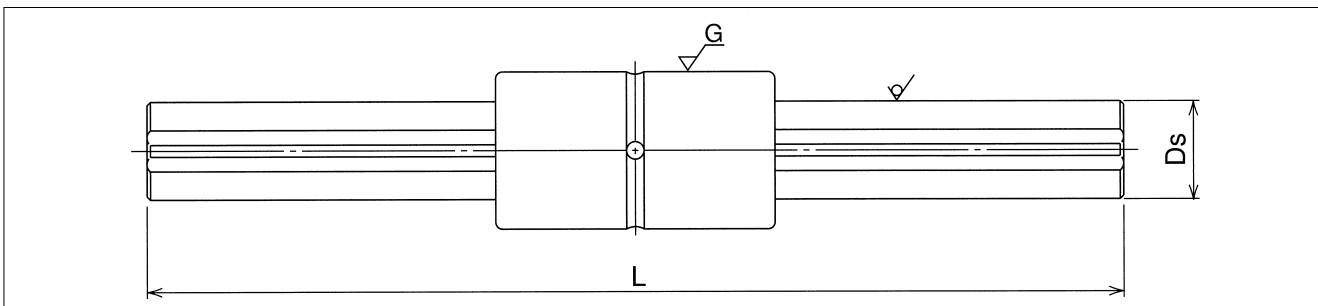
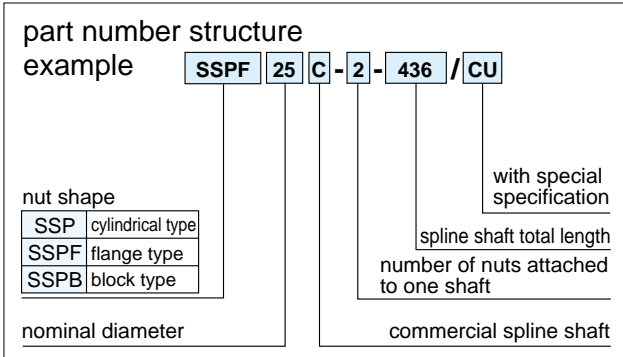
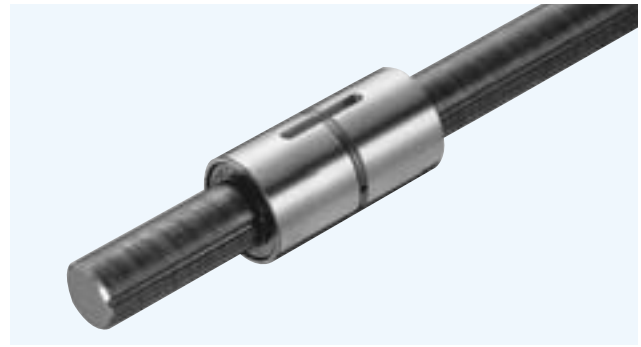

nominal diameter	major dimensions							applicable nut						
	Ds mm	standard length L mm						SSP	SSPM	SSPF	SSPT	SPA	SPA-W	SSPB
		500	1,000	2,000	3,000	4,000	5,000							
20	18.2	500	1,000	2,000	3,000	4,000	5,000	<input type="radio"/>	-	<input type="radio"/>	-	-	-	<input type="radio"/>
25	23	500	1,000	2,000	3,000	4,000	5,000	<input type="radio"/>	-	<input type="radio"/>	-	-	-	<input type="radio"/>
30	28	500	1,000	2,000	3,000	4,000	5,000	<input type="radio"/>	-	<input type="radio"/>	-	-	-	<input type="radio"/>
40	37.4	500	1,000	2,000	3,000	4,000	5,000	<input type="radio"/>	-	<input type="radio"/>	-	-	-	<input type="radio"/>
50	47	500	1,000	2,000	3,000	4,000	5,000	<input type="radio"/>	-	<input type="radio"/>	-	-	-	-

- tolerance of total length and length of splined portion yes - no
 - total length less than 4000: JIS B0405 coarse grade
 - total length greater than 4,000: +/- 5.0mm
- Please specify for tolerances other than those above.
- Refer to dimensional tables for nut shape and dimensions
- When a commercial shaft is used, the rated load for the nut is about 70% that indicated in the dimensional tables.