

SWA TYPE

– Block Type –

(Inch Series)

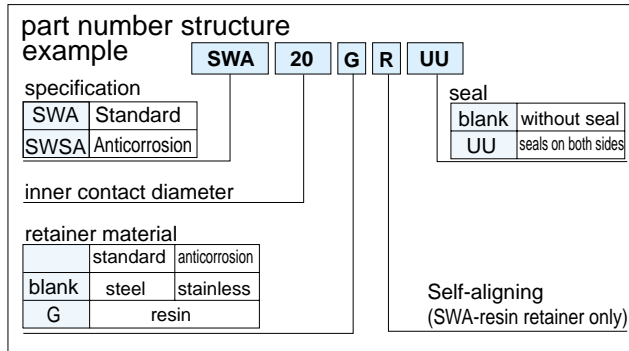
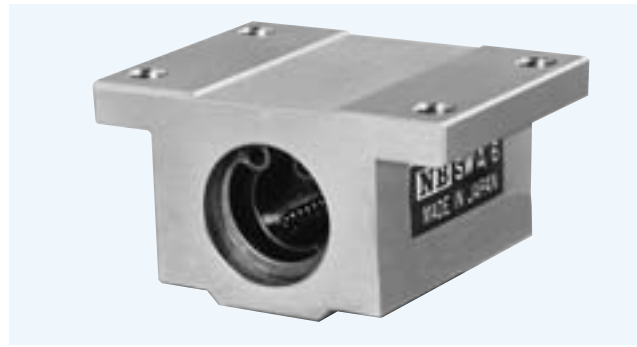

part number	major dimensions							
	inner contact diameter		outer dimensions					
	inch/mm	tolerance inch/ μ m	h $\pm .001/\pm 0.02$ inch/mm	E $\pm .001/\pm 0.02$ inch/mm	W inch/mm	L inch/mm	F inch/mm	T inch/mm
SWA 4GUU	.2500 6.350	0 - .00040	.4370 11.100	.8125 20.638	1.625 41.28	1.188 30.16	.813 20.64	.188 4.76
SWA 6GUU	.3750 9.525		.5000 12.700	.8750 22.225	1.750 44.45	1.313 33.34	.938 23.82	.188 4.76
SWA 8GUU	.5000 12.700		.6870 17.450	1.0000 25.400	2.000 50.80	1.688 42.86	1.250 31.75	.250 6.35
SWA 10GUU	.6250 15.875	0 -9	.8750 22.225	1.2500 31.750	2.500 63.50	1.938 49.21	1.625 41.28	.281 7.14
SWA 12GUU	.7500 19.050	0 - .00040	.9370 23.800	1.3750 34.925	2.750 69.85	2.063 52.39	1.750 44.45	.313 7.94
SWA 16GUU	1.0000 25.400	0 -10	1.1870 30.150	1.6250 41.275	3.250 82.55	2.813 71.44	2.188 55.56	.375 9.53
SWA 20GUU	1.2500 31.750	0 - .00050	1.5000 38.100	2.0000 50.800	4.000 101.60	3.625 92.08	2.813 71.44	.438 11.11
SWA 24GUU	1.5000 38.100	0 - .00050	1.7500 44.450	2.3750 60.325	4.750 120.65	4.000 101.60	3.250 82.55	.500 12.70
SWA 32GUU	2.0000 50.800	0 -12	2.1250 53.975	3.0000 76.200	6.000 152.40	5.000 127.00	4.063 103.19	.625 15.88

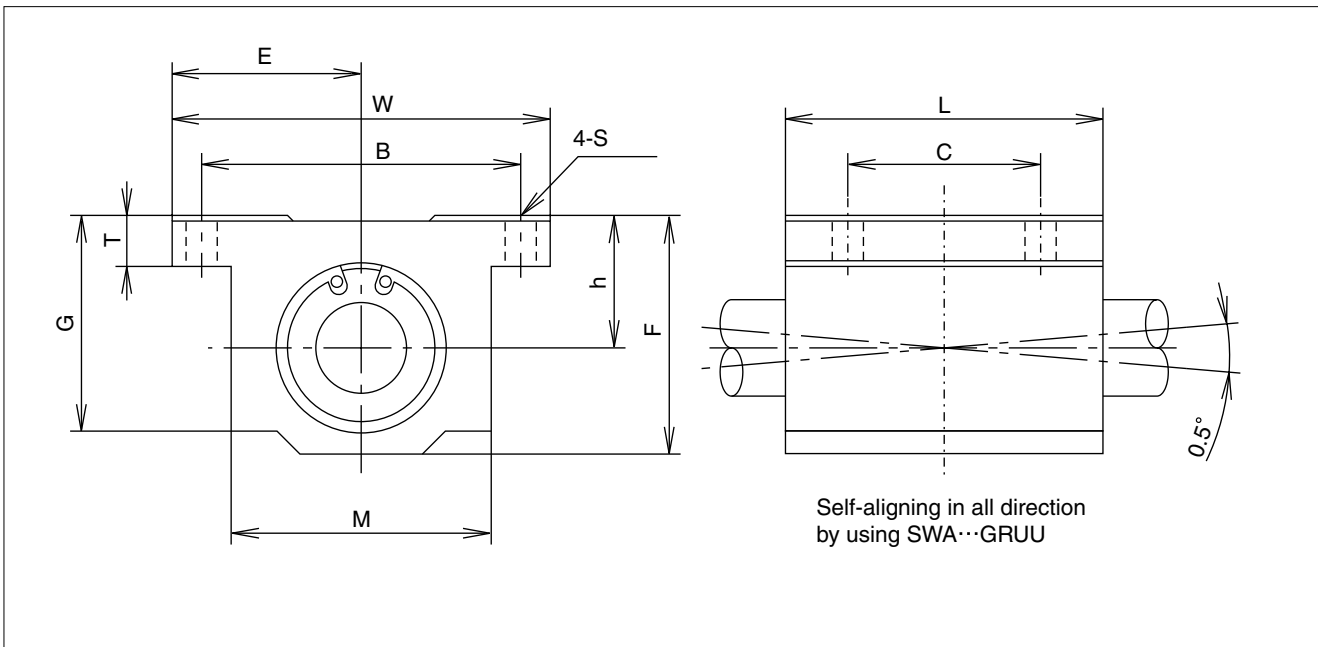

G	M	mounting dimension			basic load rating		mass	part number
		B	C	S	dynamic	static		
inch/mm	inch/mm	$\pm.01/\pm 0.2$ inch/mm	$\pm.01/\pm 0.2$ inch/mm	inch/mm	C	Co	g	
.750 19.05	1.000 25.40	1.312 33.33	.750 19.05	.156 4.0	206	265	45	SWA 4GUU
.875 22.23	1.125 28.58	1.437 36.50	.875 22.23	.156 4.0	225	314	62	SWA 6GUU
1.125 28.58	1.375 34.93	1.688 42.88	1.000 25.40	.156 4.0	510	784	130	SWA 8GUU
1.437 36.50	1.750 44.45	2.125 53.98	1.125 28.58	.188 4.8	774	1,180	240	SWA 10GUU
1.563 39.69	1.875 47.63	2.375 60.33	1.250 31.75	.188 4.8	862	1,370	290	SWA 12GUU
1.938 49.21	2.375 60.33	2.875 73.03	1.750 44.45	.219 5.6	980	1,570	615	SWA 16GUU
2.500 63.50	3.000 76.20	3.500 88.90	2.000 50.80	.219 5.6	1,570	2,740	1,300	SWA 20GUU
2.875 73.03	3.500 88.90	4.125 104.78	2.500 63.50	.281 7.2	2,160	4,020	1,900	SWA 24GUU
3.625 92.08	4.500 114.30	5.250 133.35	3.250 82.55	.406 10.5	3,820	7,940	3,600	SWA 32GUU

SI UNIT 1N \approx 0.225lbs
1kg \approx 2.205lbs

SWJ TYPE

– Clearance Adjustable Block Type –
(Inch Series)



part number structure		example		SWJ	20	G	R	UU	
specification								seal	
SWJ	Standard							blank	without seal
SWSJ	Anticorrosion							UU	seals on both sides
inner contact diameter									
retainer material									
	standard	anticorrosion							
blank	steel	stainless							
G	resin								
								Self-aligning (SWA-resin retainer only)	

part number	major dimensions						
	inner contact diameter	outer dimensions					
		h	E	W	L	F	T
inch/mm	$\pm.001/\pm 0.02$ inch/mm	$\pm.001/\pm 0.02$ inch/mm	inch/mm	inch/mm	inch/mm	inch/mm	
SWJ 8GUU	.5000 12.700	.6870 17.450	1.0000 25.400	2.000 50.80	1.688 42.86	1.250 31.75	.250 6.35
SWJ 10GUU	.6250 15.875	.8750 22.225	1.2500 31.750	2.500 63.50	1.938 49.21	1.625 41.28	.281 7.14
SWJ 12GUU	.7500 19.050	.9370 23.800	1.3750 34.925	2.750 69.85	2.063 52.39	1.750 44.45	.313 7.94
SWJ 16GUU	1.0000 25.400	1.1870 30.150	1.6250 41.275	3.250 82.55	2.813 71.44	2.188 55.56	.375 9.53
SWJ 20GUU	1.2500 31.750	1.5000 38.100	2.0000 50.800	4.000 101.60	3.625 92.08	2.813 71.44	.438 11.11
SWJ 24GUU	1.5000 38.100	1.7500 44.450	2.3750 60.325	4.750 120.65	4.000 101.60	3.250 82.55	.500 12.70
SWJ 32GUU	2.0000 50.800	2.1250 53.975	3.0000 76.200	6.000 152.40	5.000 127.00	4.063 103.19	.625 15.88

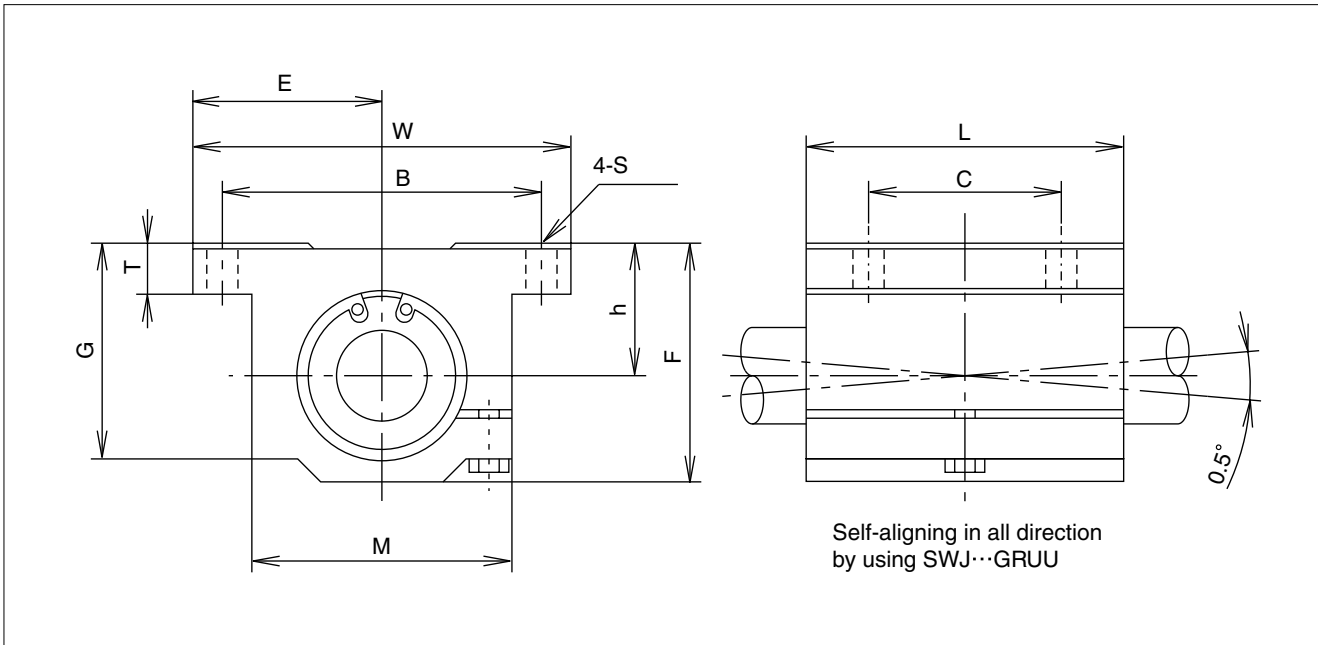

					basic load rating		mass	part number
		mounting dimensions			dynamic	static		
G	M	B	C	S	C	Co		
inch/mm	inch/mm	$\pm .01/\pm 0.2$ inch/mm	$\pm .01/\pm 0.2$ inch/mm	inch/mm	N	N	g	
1.125 28.58	1.375 34.93	1.688 42.88	1.000 25.40	.156 4.0	510	784	130	SWJ 8GUU
1.437 36.50	1.750 44.45	2.125 53.98	1.125 28.58	.188 4.8	774	1,180	240	SWJ 10GUU
1.563 39.69	1.875 47.63	2.375 60.33	1.250 31.75	.188 4.8	862	1,370	290	SWJ 12GUU
1.938 49.21	2.375 60.33	2.875 73.03	1.750 44.45	.219 5.6	980	1,570	615	SWJ 16GUU
2.500 63.50	3.000 76.20	3.500 88.90	2.000 50.80	.219 5.6	1,570	2,740	1,300	SWJ 20GUU
2.875 73.03	3.500 88.90	4.125 104.78	2.500 63.50	.281 7.2	2,160	4,020	1,900	SWJ 24GUU
3.625 92.08	4.500 114.30	5.250 133.35	3.250 82.55	.406 10.5	3,820	7,940	3,600	SWJ 32GUU

SI UNIT 1N \approx 0.225lbs

1kg \approx 2.205lbs

SWD TYPE

– Open Block Type –

(Inch Series)

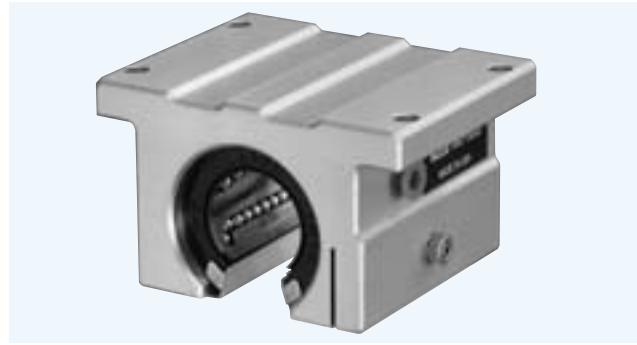

part number structure		example		SWD		20		G		R		UU			
specification		SWD		Standard		SWS		Anticorrosion		seal		blank		without seal	
inner contact diameter		retainer material		blank		steel		stainless		UU		seals on both sides		Self-aligning (SWA-resin retainer only)	
G		resin													

part number	major dimensions								
	inner contact diameter	outer dimensions						T	G
		h	E	W	L	F			
inch/mm	$\pm.001/\pm 0.02$ inch/mm	$\pm.001/\pm 0.02$ inch/mm	inch/mm	inch/mm	inch/mm	inch/mm	inch/mm	inch/mm	
SWD 8GUU	.5000 12.700	.6870 17.450	1.0000 25.400	2.000 50.80	1.500 38.10	1.100 27.94	.250 6.35	.688 17.5	
SWD 10GUU	.6250 15.875	.8750 22.225	1.2500 31.750	2.500 63.50	1.750 44.45	1.375 34.93	.281 7.14	.875 22.23	
SWD 12GUU	.7500 19.050	.9370 23.800	1.3750 34.950	2.750 69.85	1.875 47.63	1.535 39.00	.315 8.00	.937 23.80	
SWD 16GUU	1.0000 25.400	1.1870 30.150	1.6250 41.300	3.250 82.55	2.625 66.68	1.975 50.17	.375 9.53	1.188 30.18	
SWD 20GUU	1.2500 31.750	1.5000 38.100	2.0000 50.800	4.000 101.60	3.375 85.73	2.485 63.12	.437 11.10	1.500 38.10	
SWD 24GUU	1.5000 38.100	1.7500 44.450	2.3750 60.325	4.750 120.65	3.750 95.25	2.910 73.90	.500 12.70	1.750 44.45	
SWD 32GUU	2.0000 50.800	2.1250 53.975	3.0000 76.200	6.000 152.4	4.750 120.65	3.660 92.90	.625 15.88	2.250 57.15	

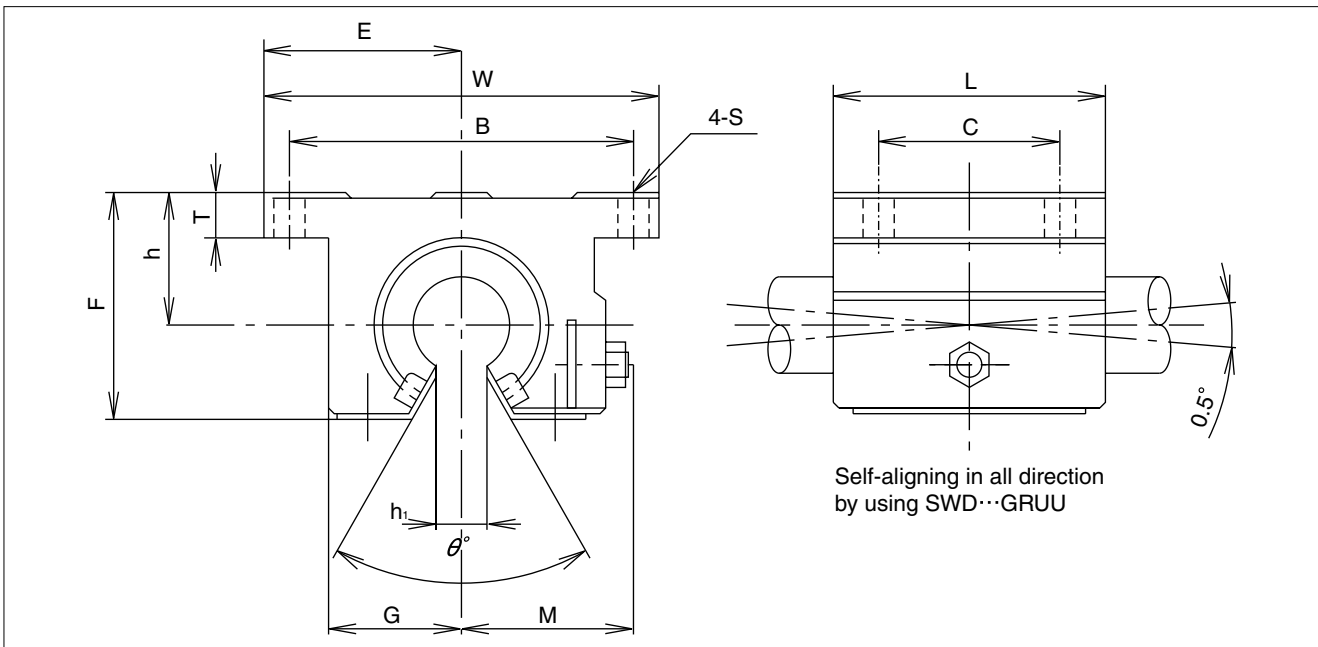

			mounting dimensions			basic load rating		mass	Part number
M	h ₁	θ	B	C	S	dynamic C	static C ₀	g	
inch/mm	inch/mm		±.01/±0.2 inch/mm	±.01/±0.2 inch/mm	inch/mm	N	N		
.98 24.89	.3425 8.70	80°	1.688 42.88	1.000 25.40	.156 4.0	510	784	98	SWD 8GUU
1.15 29.21	.375 9.53	80°	2.125 53.98	1.125 28.58	.188 4.8	774	1,180	185	SWD 10GUU
1.23 31.24	.4375 11.11	60°	2.375 60.33	1.250 31.75	.188 4.8	862	1,370	235	SWD 12GUU
1.48 37.59	.5625 14.29	50°	2.875 73.03	1.750 44.45	.218 5.6	980	1,570	530	SWD 16GUU
1.88 47.75	.625 15.88	50°	3.500 88.90	2.000 50.80	.218 5.6	1,570	2,740	1,080	SWD 20GUU
2.12 53.85	.750 19.05	50°	4.125 104.78	2.500 63.50	.281 7.4	2,160	4,020	1,620	SWD 24GUU
2.70 68.58	1.00 25.40	50°	5.250 133.35	3.250 82.55	.406 10.5	3,820	7,940	3,100	SWD 32GUU

SI UNIT 1N ≙ 0.225lbs

1kg ≙ 2.205lbs

