

MARYLAND METRICS

phones: (410)358-3130 (800)638-1830

faxes: (410)358-3142 (800)872-9329

P.O.Box 261 Owings Mills, MD 21117 USA

Internet: <http://mdmetric.com>

E-mail: sales@mdmetric.com

SLIDE SHAFT

SLIDE GUIDE

BALL SPLINE
ROTARY BALL SPLINE

TOPBALL® PRODUCTS

SLIDE BUSH

SLIDE UNIT

STROKE BUSH
SLIDE ROTARY BUSH

SLIDE SHAFT

SLIDE WAY
SLIDE TABLE
GONIO WAY

ACTUATOR

SLIDE SCREW

SNW-PD

— NB Inch Pre-Drilled Shaft —

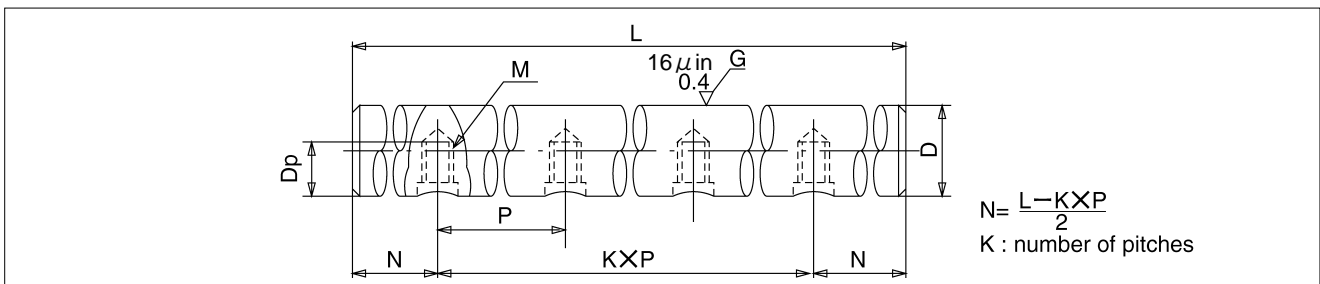
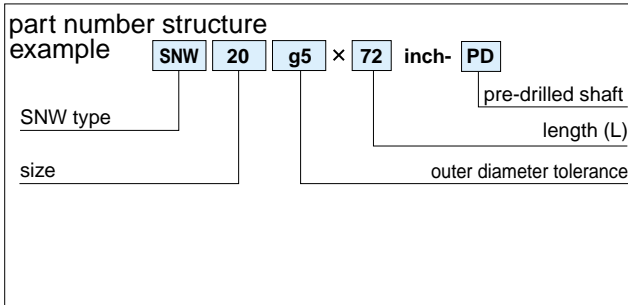
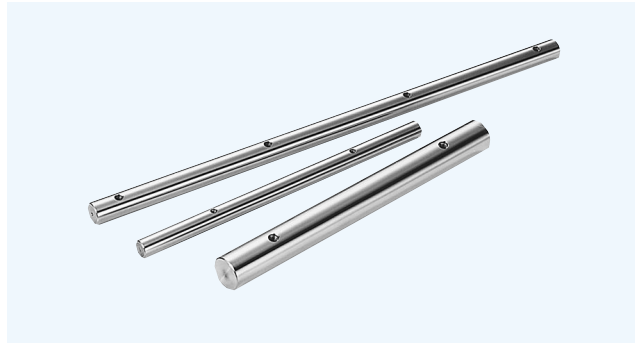

part number	outer diameter		pitch P inch/mm	bolt size M	tapped hole depth Dp inch/mm	maximum length L inch/mm
	D inch mm	tolerance g5* inch/μm				
SNW 8-PD	1/2 12.700	-.0002 -.0006	4 101.6	# 6-32	0.280 7.1	72 1,828.8
SNW10-PD	5/8 15.875	-6 -14		8-32	0.350 8.9	
SNW12-PD	3/4 19.050	-.0003 -.0006	6 152.4	10-32	0.400 10.2	
SNW16-PD	1 25.400	-7 -16		1/4-20	0.500 12.7	
SNW20-PD	1-1/4 31.750	-.0004 -.0008		5/16-18	0.650 16.5	
SNW24-PD	1-1/2 38.100	-9 -20	8 203.2	3/8-16	0.700 17.8	
SNW32-PD	2 50.800	-.0004/- .0010 -10/-23		1/2-13	0.850 21.6	

material : high-carbon chromium bearing steel (SUJ2) .

1kg ≅ 2.205 lb

hardness : HV 697 (60HRC) or more

Tolerances other than *g5 are available upon request.

Longer length are also available.

SNWS-PD

– NB Inch Pre-Drilled Stainless Steel Shaft –

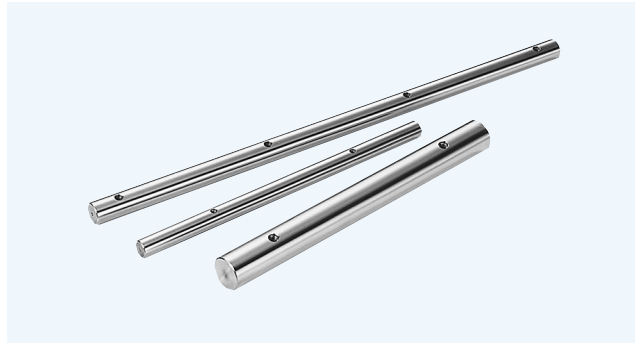

part number structure	
example	SNWS 24 g5 × 72 inch- PD
SNWS type	pre-drilled shaft
size	length (L) outer diameter tolerance

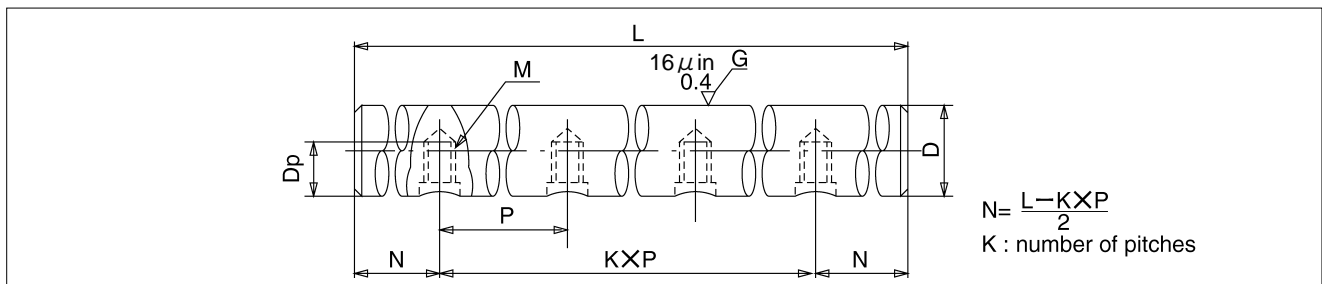

part number	outer diameter		pitch P inch/mm	bolt size M	tapped hole depth Dp inch/mm	maximum length L inch/mm
	D inch mm	tolerance g5* inch/μm				
SNWS12-PD	3/4 19,050	-.0003 -.0006	6 152.4	# 10-32	0.400 10.2	72 1,828.8
SNWS16-PD	1 25,400	-7 -16		1/4-20	0.500 12.7	
SNWS20-PD	1-1/4 31,750	-.0004 -.0008		5/16-18	0.650 16.5	
SNWS24-PD	1-1/2 38,100	-9 -20	8 203.2	3/8-16	0.700 17.8	
SNWS32-PD	2 50,800	-.0004/-0.010 -10/-23		1/2-13	0.850 21.6	

material : martensite stainless steel (equivalent to SUS440C)

hardness : HV653 (58HRC) or more

Tolerances other than *g5 are available upon request.

Longer length are also available.