

SLIDE GUIDE SGW TYPE

The SGW slide guide is a linear motion bearing utilizing the rotational motion of ball elements along four rows of raceway grooves. Its low height and wide profile makes it suitable for single-rail applications.

STRUCTURE AND ADVANTAGES

SGW slide guide consists of a rail with four precision-machined raceway grooves and a block assembly. The block assembly consists of the main body, ball elements, retainers, and return caps.

High Load Capacity and Long Life:

The raceway grooves are machined to a radius close to that of the ball elements. The larger contact surface results are high load capacity and provides longer life.

High Allowable Moment:

Its wide profile enables it to sustain high moment loads, making it suitable for single-rail applications.

Omni-Directional Load Capacity:

The ball elements are positioned at 45° contact angle so that the load capacity is equal in four directions (above, underneath, right and left).

Smooth Motion:

The large number of ball elements produce a smooth rolling motion.

Anti-Corrosion Specification:

The rail and block assembly may be Raydent treated to increase the corrosion resistance. This treatment is standardized with the symbol "RD", and suitable for use in clean room applications.

Dust Prevention:

Side seals are provided as standard. To improve the dust prevention characteristics, under-seals and rail mounting caps are also available.

Figure A-53 Structure of SGW type Slide Guide

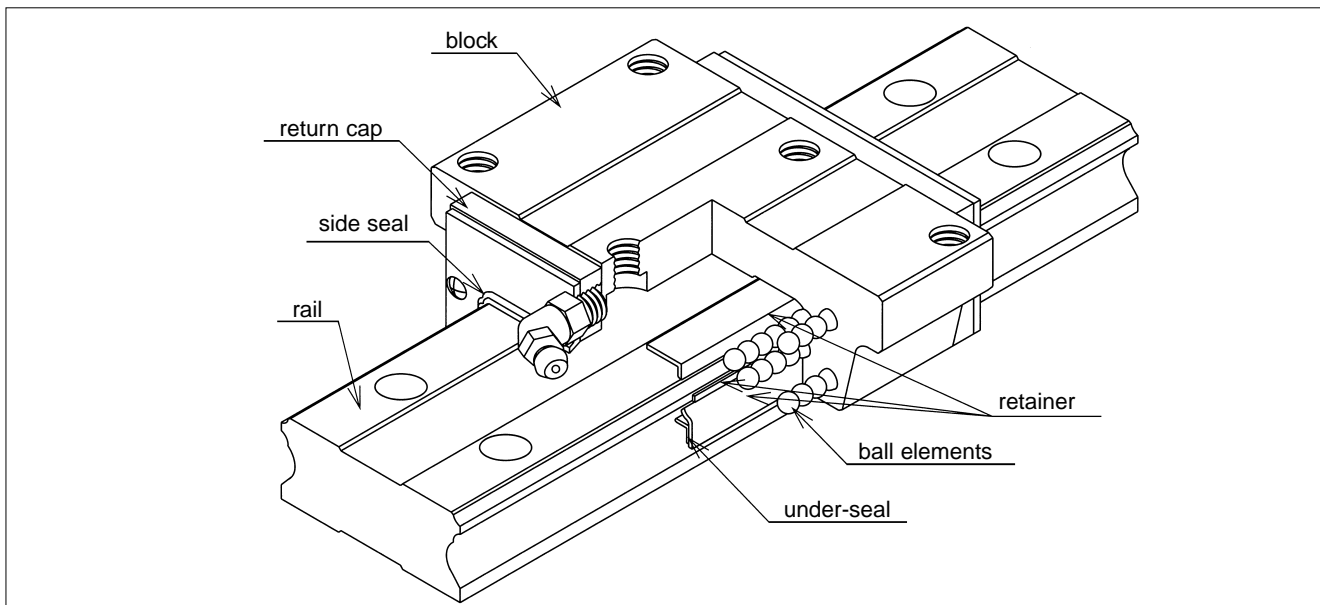

ACCURACY

Three accuracy grades are available: normal-grade (no suffix), high-grade (H), and precision-grade (P).

Table A-29 Accuracy

unit/mm

part number	SGW17,21			SGW27,35		
	normal	high	precision	normal	high	precision
accuracy grade	normal	high	precision	normal	high	precision
accuracy symbol	blank	H	P	blank	H	P
allowable dimensional tolerance for height H	±0.1	±0.03	-0.03~0	±0.1	±0.04	-0.04~0
paired difference for height H	0.02	0.01	0.006	0.02	0.015	0.007
allowable dimensional tolerance for width W	±0.1	±0.03	-0.03~0	±0.1	±0.04	-0.04~0
paired difference for width W	0.02	0.01	0.006	0.03	0.015	0.007
Running parallelism of surface C to surface A Running parallelism of surface D to surface B	refer to Figure A-54					

Figure A-54 Motion Accuracy

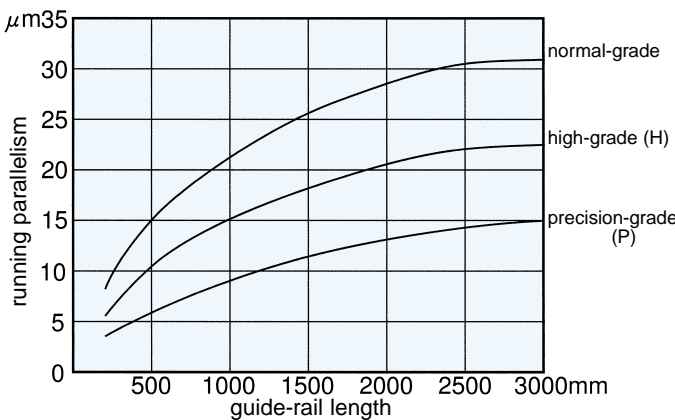
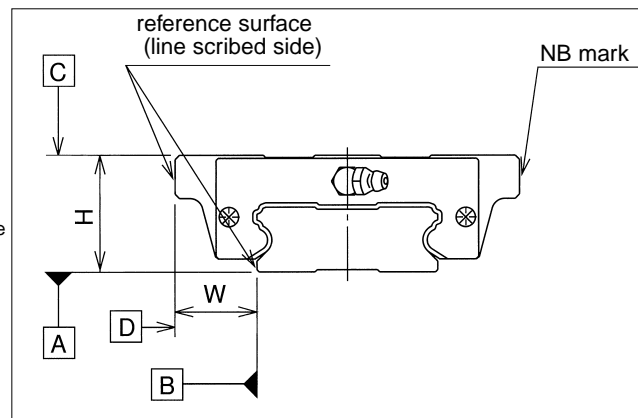

Figure A-55 Accuracy



PRE-LOAD

Three levels of pre-load are available for SGW slide guides: standard, light (T1), and medium (T2).

Table A-30 Pre-Load Call Out and Radial Clearance

unit/μm

category	standard	light	medium
symbol	blank	T1	T2
SGW17	-3~+2	-7~-3	-
SGW21	-4~+2	-8~-4	-
SGW27	-5~+2	-11~-5	-
SGW35	-8~+4	-18~-8	-28~-18

Table A-31 Operating Conditions and Pre-Load

pre-load category	symbol	operating condition
standard	blank	Minute vibration is applied. Precision motion is required. Moment in a given direction is applied.
light	T1	Light vibration is applied. Light torsion is applied. Moment is applied.
medium	T2	Shock/vibration is applied. Over-hang load is applied. Torsional load is applied.

RAIL LENGTH

Slide guides with most commonly used lengths are available as standard. Unless otherwise specified, the distance to the first installation hole (N) from one end of the rail will be located within the range listed in Table A-32 for slide guides that have a non-standard length satisfying the following equation.

$$L = M \cdot P + 2N$$

L : length (mm) N : distance to the first hole from the end of the rail (mm)
M : number of pitches P : hole pitch (mm)

Figure A-56 Rail

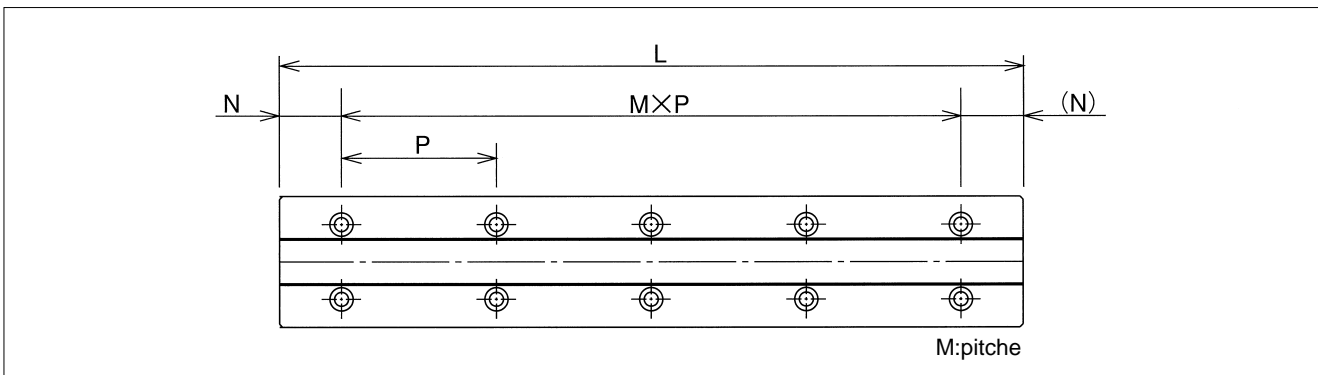

Table A-32 Rail Fabrication Range

unit/mm

part number	N		Lmax.
	and over	less than	
SGW17	8	28	2,000
SGW21		33	
SGW27		38	
SGW35	12	52	3,000

MOUNTING

Slide guides are generally mounted by pushing the reference surface of the rail and block against the shoulder of the mounting surface. To avoid interference between the shoulder and the corner of the rail or block, the shoulder should be fabricated with dimensions smaller than those listed in Table A-34.

Figure A-57 Mounting Reference Surface Shapes

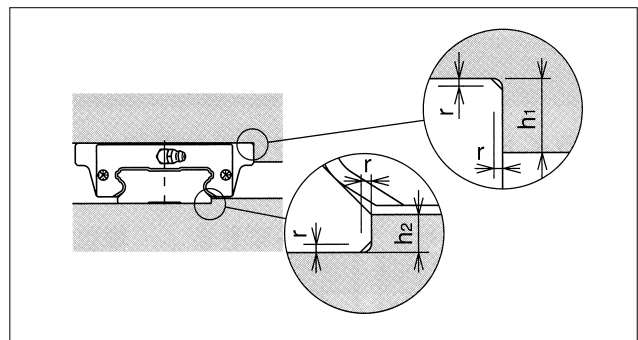

Table A-33 Recommended Torque

part number	bolt size	recommended torque (N-m)
SGW17	M4	3.9
SGW21		
SGW27		
SGW35	M6	12.7

Table A-34 Mounting Surface Dimensions

unit/mm

part number	h ₁	h ₂	r _{max.}
SGW17	4	2	0.4
SGW21	5	2.5	
SGW27		3.5	
SGW35			0.8

GREASE FITTING

A grease fitting is attached to the SGW slide guide near the return cap for lubrication purposes. Unless otherwise specified, the orientation of the grease fitting is as shown in Figure A-58. When more than 2 blocks are used on one rail, the grease fitting orientation must be specified.

Figure A-58 Number of Blocks and Grease Fitting Orientation

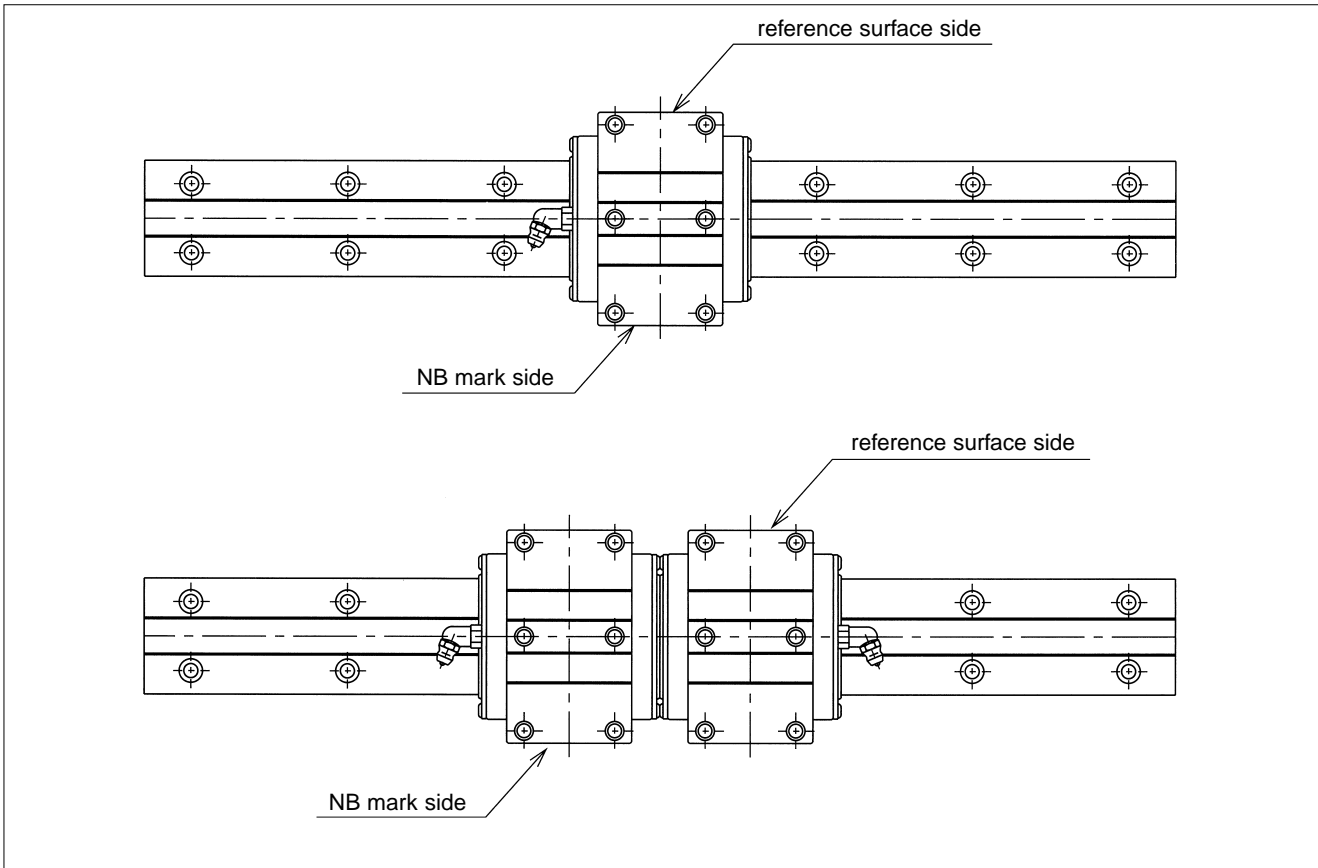

SGW-TE TYPE

– High Rigidity Wide Flange Type –

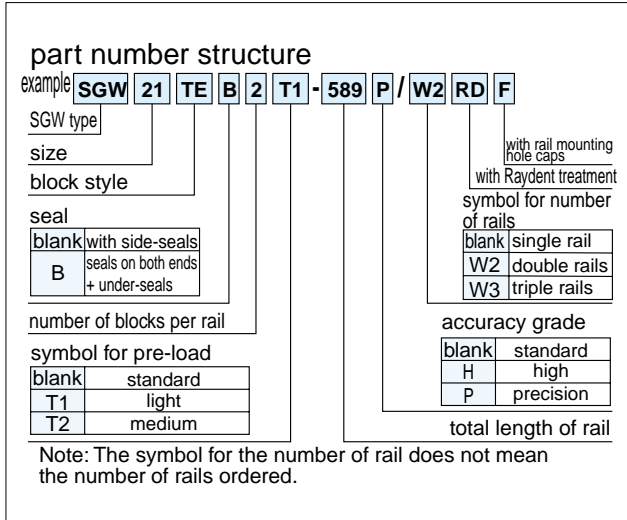
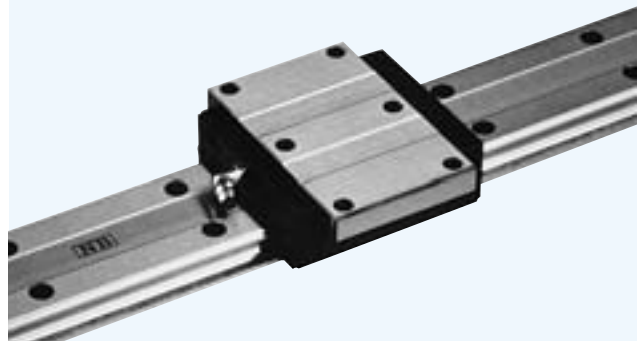

part number	assembly dimensions		block dimensions											
	H	W	B	L ₁	L ₂	P ₁	P ₂	S	D	F	T	b	E	T ₁
	mm	mm	mm	mm	mm	mm	mm		mm	mm	mm	mm	mm	mm
SGW17TE	17	13.5	60	51	33.6	53	26	M4	3.3	3.2	6	14.5	2.5	4
SGW21TE	21	15.5	68	58	40	60	29	M5	4.4	3.7	8	18	14	4.5
SGW27TE	27	19	80	71.8	51.8	70	40	M6	5.3	6	10	24		6
SGW35TE	35	25.5	120	106.6	77.6	107	60	M8	6.8	8	14	31		8

part number	standard rail length											
	L mm											
SGW17	110	150	190	230	270	310	350	390	430	510	590	
SGW21	130	180	230	280	330	380	430	480	530	630	730	
SGW27	160	220	280	340	400	460	520	640	760	880	1,000	
SGW35	280	360	440	520	600	680	760	920	1,080	1,240	1,400	

Rails exceeding the maximum specified length may be fabricated if joints are used. Contact NB for assistance.

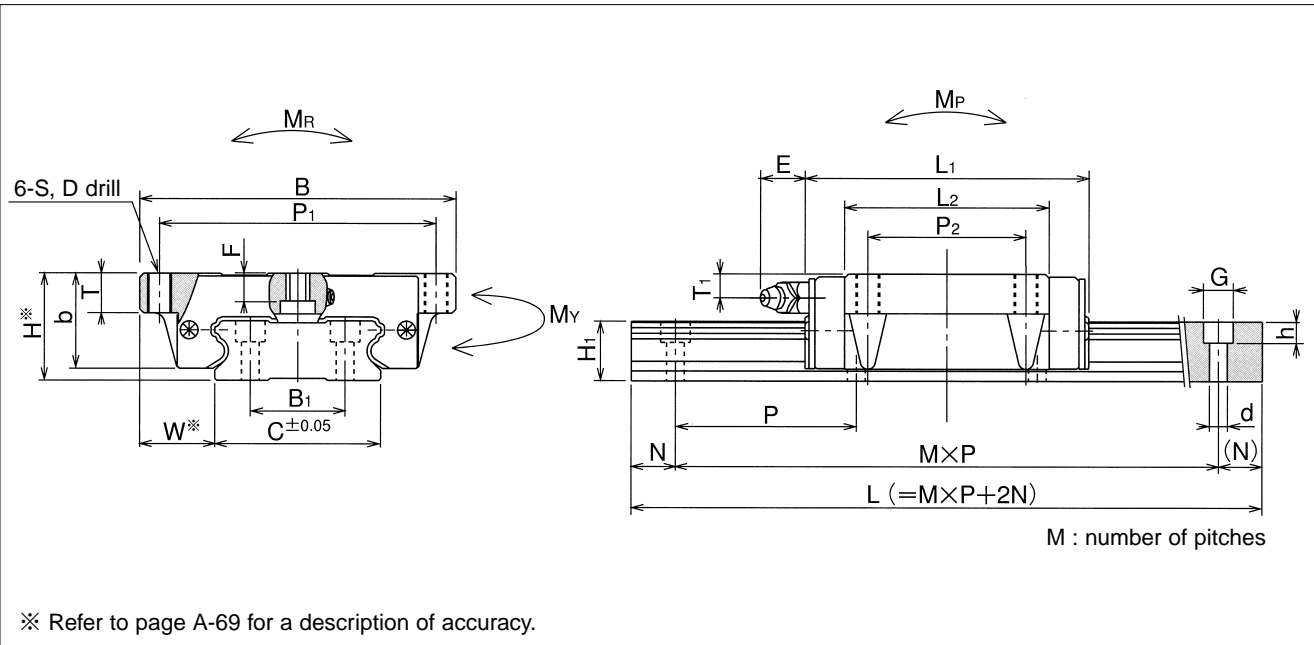

grease fitting	guide-rail dimensions						basic load rating		allowable static moment			mass		size
	H _i	C	B ₁	d × G × h	N	P	dynamic C	static Co	M _P	M _Y	M _R	block	guide rail	
	mm	mm	mm	mm	mm	mm	kN	kN	N · m	N · m	N · m	kg	kg/m	
pressed fitting	9	33	18	4.5 × 7.5 × 5.3	15	40	4.9	8.7	51	51	145	0.14	2.05	17
B-M6F	11	37	22			50	7	12	80	80	220	0.23	2.84	21
	15	42	24	20	60	13	21	190	190	450	0.46	4.43	27	
	19	69	40		7 × 11 × 9	80	29.0	48	630	630	1,650	1.35	9.32	35

1kN ≒ 102kgf 1N·m ≒ 0.102kgf·m

								maximum length mm
670	750	830	950	1,070	1,190	1,310		2,000
830	930	1,030	1,180	1,330	1,480			2,000
1,180	1,360	1,540	1,720	1,900				3,000
1,640	1,880	2,120						3,000